

Complexity Analysis of Continuous Petri Nets

Estíbaliz Fraca*

Instituto de Investigación en Ingeniería de Aragón (I3A)
Universidad de Zaragoza, Zaragoza, Spain
E-mail: efrac@unizar.es

Serge Haddad†

Ecole Normale Supérieure de Cachan,
LSV, CNRS UMR 8643, INRIA, Cachan, France
E-mail: haddad@lsv.ens-cachan.fr

Abstract. At the end of the eighties, continuous Petri nets were introduced for: (1) alleviating the combinatorial explosion triggered by discrete Petri nets and, (2) modelling the behaviour of physical systems whose state is composed of continuous variables. Since then several works have established that the computational complexity of deciding some standard behavioural properties of Petri nets is reduced in this framework. Here we first establish the decidability of additional properties like coverability, boundedness and reachability set inclusion. We also design new decision procedures for reachability and lim-reachability problems with a better computational complexity. Finally we provide lower bounds characterising the exact complexity class of the reachability, the coverability, the boundedness, the deadlock freeness and the liveness problems. A small case study is introduced and analysed with these new procedures.

Keywords: Continuous Petri nets, structural analysis, complexity

1. Introduction

From Petri nets to continuous Petri nets. Continuous Petri nets (CPN) were introduced in [5] by considering continuous states (specified by a nonnegative real number of tokens in places) where the

Address for correspondence: haddad@lsv.ens-cachan.fr

*This work has been partially supported by CICYT - FEDER project DPI2010-20413.

†This work has been partially supported by ImpRo (ANR-2010-BLAN-0317).

dynamics of the system is triggered either by discrete events or by a continuous evolution ruled by speed of firings. In the former case such nets are called autonomous CPNs while in the latter they are called timed CPNs. In both cases, the evolution is due to a *fractional* transition firing (infinitesimal and simultaneous in the case of timed CPNs).

Modelling with CPNs. CPNs have been used in several significant application fields. In [3], a method based on CPNs is proposed for the fault diagnosis of manufacturing systems while such a diagnosis is intractable with discrete Petri nets (for modelling of manufacturing systems see also [18]). In [16], the authors introduce a bottom-up modelling methodology based on CPNs to represent cell metabolism and solve in this framework the regulation control problem. Combining discrete and continuous Petri nets yields hybrid Petri nets with applications to modelling and simulation of water distribution systems [9] and to the analysis of traffic in urban networks [17].

Analysis of CPNs. While several analysis methods have been developed for timed CPNs there is no hope for fully automatic techniques in the general case since standard problems of dynamic systems are known to be undecidable even for bounded nets [14].

Due to the semantics of autonomous CPNs, a marking can be the limit of the markings visited along an infinite firing sequence. Thus most of the usual properties are duplicated depending on whether these markings are considered or not. Taking into account these markings, reachability (resp. liveness, deadlock-freeness) becomes lim-reachability (resp. lim-liveness, lim-deadlock-freeness).

Contrary to the timed case, the analysis of autonomous CPNs (that we simply call CPNs in the sequel) appears to be less complex than the one of discrete Petri nets. In [10], exponential time decision procedures are proposed for the reachability and lim-reachability problems for general CPNs. In [15] assuming additional hypotheses on the net, the authors design polynomial time decision procedures for (lim-)reachability and boundedness. In [14], (lim-)deadlock-freeness and (lim-)liveness are shown to belong in coNP. These procedures are based on “simple” characterisations of the properties.

Our contributions. First we revisit characterisations of properties in CPN establishing an alternative characterisation for reachability and the first characterisation for coverability and boundedness. Then based on these characterisations, we show that (lim-)reachability, (lim-)coverability and boundedness are decidable in polynomial time. We also establish that the (lim-)reachability set inclusion problem is decidable in exponential time. Finally we prove that (lim-)reachability, (lim-)coverability and boundedness are PTIME-hard and that (lim-)deadlock-freeness, (lim-)liveness and (lim-)reachability set inclusion problems are coNP-hard. We establish these lower bounds even when considering restricted cases of these problems.

Organisation. In Section 2, we introduce CPNs and the properties that we are analysing. In Section 3, we develop the characterisations of reachability, coverability and boundedness. Afterwards in Section 4, we design the decision procedures. Then, we provide complexity lower bounds in Section 5. In Section 6 we illustrate our results with a small case study. Finally in Section 7, we summarise our results and give perspectives to this work.

2. Continuous Petri nets: definitions and properties

2.1. Continuous Petri nets

Notations. \mathbb{N} (resp. \mathbb{Q} , \mathbb{R}) is the set of nonnegative integers (resp. rational, real numbers). Given a set

of numbers E , $E_{\geq 0}$ (resp. $E_{>0}$) denotes the subset of nonnegative (resp. positive) numbers of E . Given an $E \times F$ matrix \mathbf{M} with E and F sets of indices, $E' \subseteq E$ and $F' \subseteq F$, the $E' \times F'$ submatrix $\mathbf{M}_{E' \times F'}$ denotes the restriction of \mathbf{M} to rows indexed by E' and columns indexed by F' . The support of a vector $\mathbf{v} \in \mathbb{R}^E$, denoted $\llbracket \mathbf{v} \rrbracket$, is defined by $\llbracket \mathbf{v} \rrbracket \stackrel{\text{def}}{=} \{e \in E \mid \mathbf{v}[e] \neq 0\}$. $\mathbf{0}$ denotes the null vector. One writes $\mathbf{v} \geq \mathbf{w}$ when \mathbf{v} is componentwise greater or equal than \mathbf{w} and $\mathbf{v} \succcurlyeq \mathbf{w}$ when $\mathbf{v} \geq \mathbf{w}$ and $\mathbf{v} \neq \mathbf{w}$. One writes $\mathbf{v} > \mathbf{w}$ when \mathbf{v} is componentwise strictly greater than \mathbf{w} . $\|\mathbf{v}\|_1$ is the 1-norm of \mathbf{v} defined by $\|\mathbf{v}\|_1 \stackrel{\text{def}}{=} \sum_{e \in E} |\mathbf{v}[e]|$. Let $E' \subseteq E$, then $\mathbf{v}[E']$ denotes the restriction of \mathbf{v} to components of E' .

Here, we adopt the following terminology: a *net* denotes the structure without initial marking while a *net system* denotes a net with an initial marking. The structure of CPNs and discrete nets are identical.

Definition 1. A Petri net (PN) is a tuple $\mathcal{N} = \langle P, T, \mathbf{Pre}, \mathbf{Post} \rangle$ where:

- P is a finite set of places;
- T is a finite set of transitions, with $P \cap T = \emptyset$;
- \mathbf{Pre} (resp. \mathbf{Post}), is the backward (resp. forward) $P \times T$ incidence matrix, whose items belong to \mathbb{N} .

The incidence matrix \mathbf{C} is defined by $\mathbf{C} \stackrel{\text{def}}{=} \mathbf{Post} - \mathbf{Pre}$.

Given a place (resp. transition) v in P (resp. in T), its *preset*, $\bullet v$, is defined as the set of its input transitions (resp. places): $\bullet v \stackrel{\text{def}}{=} \{t \in T \mid \mathbf{Post}[v, t] > 0\}$ (resp. $\bullet v \stackrel{\text{def}}{=} \{p \in P \mid \mathbf{Pre}[p, v] > 0\}$). Its *postset* $v\bullet$ is defined as the set of its output transitions (resp. places): $v\bullet \stackrel{\text{def}}{=} \{t \in T \mid \mathbf{Pre}[v, t] > 0\}$ (resp. $v\bullet \stackrel{\text{def}}{=} \{p \in P \mid \mathbf{Post}[p, v] > 0\}$). This notion generalizes to a subset V of places (resp. transitions) by: $\bullet V \stackrel{\text{def}}{=} \bigcup_{v \in V} \bullet v$ and $V\bullet \stackrel{\text{def}}{=} \bigcup_{v \in V} v\bullet$. In addition, $\bullet V\bullet \stackrel{\text{def}}{=} \bullet V \cup V\bullet$.

Given $T' \subseteq T$, $\mathcal{N}_{T'}$ is the subnet of \mathcal{N} such that its set of transitions is T' and its set of places is $\bullet T'\bullet$, and its backward and forward incidence matrices are respectively $\mathbf{Pre}_{\bullet T'\bullet \times T'}$ and $\mathbf{Post}_{T' \times \bullet T'\bullet}$.

We define \mathcal{N}^{-1} as the “reverse” net of \mathcal{N} , in which the places and transitions coincide, and its arcs are inverted.

Definition 2. Given a PN $\mathcal{N} = \langle P, T, \mathbf{Pre}, \mathbf{Post} \rangle$, its *reverse net* \mathcal{N}^{-1} is defined by: $\mathcal{N}^{-1} \stackrel{\text{def}}{=} \langle P, T, \mathbf{Post}, \mathbf{Pre} \rangle$.

A *continuous* PN system, denoted CPN system, consists of a net and a nonnegative real marking. A CPN is a CPN system without initial marking.

Definition 3. A CPN system is a tuple $\langle \mathcal{N}, \mathbf{m}_0 \rangle$ where \mathcal{N} is a PN and $\mathbf{m}_0 \in \mathbb{R}_{\geq 0}^P$ is the initial marking.

When a CPN system is an input of a decision problem, the items of \mathbf{m}_0 are rational numbers in order to characterise the complexity of the problem.

In discrete PNs the firing rule of a transition requires tokens specified by \mathbf{Pre} to be present in the corresponding places. In continuous PNs a nonnegative real *amount* of transition firing is allowed and this amount scales the requirement expressed by \mathbf{Pre} and \mathbf{Post} .

Definition 4. Let \mathcal{N} be a CPN, t be a transition and $\mathbf{m} \in \mathbb{R}_{\geq 0}^P$ be a marking.

- The *enabling degree* of t w.r.t. \mathbf{m} , $enab(t, \mathbf{m}) \in \mathbb{R}_{\geq 0} \cup \infty$, is defined by:
 $enab(t, \mathbf{m}) \stackrel{\text{def}}{=} \min\{\frac{\mathbf{m}[p]}{Pre[p,t]} \mid p \in \bullet t\}$ ($enab(t, \mathbf{m}) = \infty$ iff $\bullet t = \emptyset$).
- t is *enabled* in \mathbf{m} if $enab(t, \mathbf{m}) > 0$.
- t can be *fired* by any amount $\alpha \in \mathbb{R}$ such that¹ $0 \leq \alpha \leq enab(t, \mathbf{m})$, and its firing leads to marking \mathbf{m}' defined by: for all $p \in P$, $\mathbf{m}'[p] \stackrel{\text{def}}{=} \mathbf{m}[p] + \alpha C[p, t]$.

The firing of t from \mathbf{m} by an amount α leading to \mathbf{m}' is denoted as $\mathbf{m} \xrightarrow{\alpha t} \mathbf{m}'$. We illustrate the firing rule of a CPN with the CPN system in Fig. 1(a) (example taken from [10]). In the initial marking $\mathbf{m}_0 = (1, 0, 1, 0)$, only transition t_1 is enabled and its enabling degree is 1. Hence, it can be fired by any real amount α s.t. $0 \leq \alpha \leq 1$. If t_1 is fired by an amount of 0.5, marking $\mathbf{m}_1 = (0.5, 0.5, 1, 0)$ is reached. In \mathbf{m}_1 , transitions t_1 and t_2 are enabled, with enabling degree both equal to 0.5.

Let $\sigma = \alpha_1 t_1 \dots \alpha_n t_n$ be a finite sequence with for all i , $t_i \in T$ and $\alpha_i \in \mathbb{R}_{\geq 0}$. σ is *firable* from \mathbf{m}_0 if for all $1 \leq i \leq n$ there exist \mathbf{m}_i such that $\mathbf{m}_{i-1} \xrightarrow{\alpha_i t_i} \mathbf{m}_i$. This firing is denoted by $\mathbf{m}_0 \xrightarrow{\sigma} \mathbf{m}_n$. When the destination marking is irrelevant we omit it and simply write $\mathbf{m}_0 \xrightarrow{\sigma}$. Let $\sigma = \alpha_1 t_1 \dots \alpha_n t_n \dots$ be an infinite sequence then σ is *firable* from \mathbf{m}_0 if for all n , $\alpha_1 t_1 \dots \alpha_n t_n$ is firable from \mathbf{m}_0 . This firing is denoted as $\mathbf{m}_0 \xrightarrow{\sigma} \infty$.

Given a finite or infinite sequence $\sigma = \alpha_1 t_1 \dots \alpha_i t_i \dots$ and $\alpha \in \mathbb{R}_{\geq 0}$, the sequence $\alpha\sigma$ is defined by $\alpha\sigma \stackrel{\text{def}}{=} \alpha\alpha_1 t_1 \dots \alpha\alpha_i t_i \dots$. Given two infinite sequences $\sigma = \alpha_1 t_1 \dots \alpha_i t_i \dots$ and $\sigma' = \alpha'_1 t'_1 \dots \alpha'_i t'_i \dots$, the (non commutative) sum $\sigma + \sigma'$ is defined by: $\sigma + \sigma' \stackrel{\text{def}}{=} \alpha_1 t_1 \alpha'_1 t'_1 \dots \alpha_i t_i \alpha'_i t'_i \dots$. This notion generalises to arbitrary sequences by extending them to infinite sequences with null amounts of firings (the selected transitions are irrelevant).

Let $\sigma = \alpha_1 t_1 \dots \alpha_n t_n$ be a finite sequence and denote $\sigma^{-1} = \alpha_n t_n \dots \alpha_1 t_1$. By definition of the reverse net, $\mathbf{m} \xrightarrow{\sigma} \mathbf{m}'$ in \mathcal{N} iff $\mathbf{m}' \xrightarrow{\sigma^{-1}} \mathbf{m}$ in \mathcal{N}^{-1} .

The Parikh image (also called firing count vector) of a (finite or infinite) firing sequence σ where $\sigma = \alpha_1 t_1 \dots \alpha_n t_n \dots$ denoted $\vec{\sigma} \in (\mathbb{R}_{\geq 0} \cup \{\infty\})^T$ is defined by: $\vec{\sigma}[t] \stackrel{\text{def}}{=} \sum_{i|t_i=t} \alpha_i$. As in discrete PNs, when $\mathbf{m} \xrightarrow{\sigma} \mathbf{m}'$, $\mathbf{m}' = \mathbf{m} + C\vec{\sigma}$ and this equation is called the *state equation*.

A set of places P' is a *siphon* if $\bullet P' \subseteq P'\bullet$. When a siphon does not contain tokens in some marking, it will never contain tokens after any firing sequence starting from this marking. When a siphon does not contain tokens, it is called an *empty siphon*.

An interesting difference between discrete and continuous PN systems is that the sequence of markings visited by an infinite firing sequence may converge to a given marking. For example, let us consider again the CPN system of Fig. 1(a), and the marking $\mathbf{m}_1 = (0.5, 0.5, 1, 0)$. From \mathbf{m}_1 , $0.5t_2$ can be fired, reaching $\mathbf{m}_2 = (0.5, 0.5, 0, 0.5)$. From \mathbf{m}_2 transition t_3 can be fired by an amount of 0.5, leading to $\mathbf{m}_3 = (0.5, 0.5, 0.5, 0)$. Iterating this process leads to the infinite firing sequence $\sigma = 2^{-1}t_2 2^{-1}t_3 \dots 2^{-n}t_2 2^{-n}t_3 \dots$ whose visited markings converge toward $(0.5, 0.5, 0, 0)$. Observe that the Parikh image $\vec{\sigma} = \vec{t}_2 + \vec{t}_3$ does not correspond to any finite firing sequence starting from \mathbf{m}_1 .

¹So from every marking, any (even disabled) transition can fire by a null amount without modifying the marking.

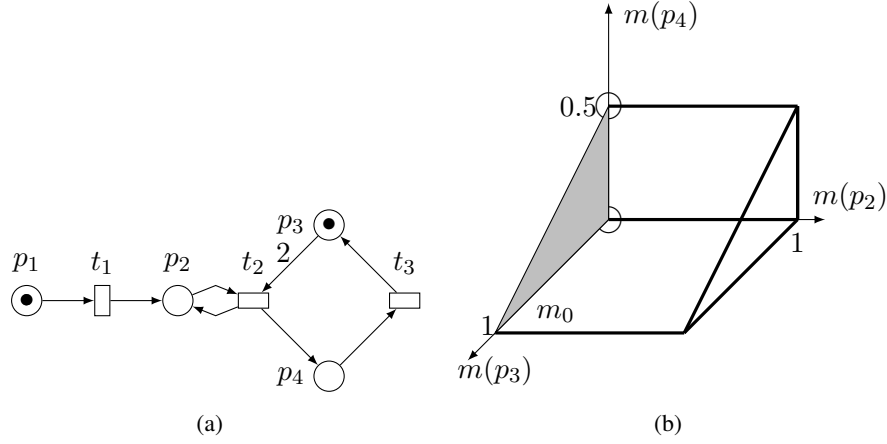

Figure 1. (a) A CPN system (b) its lim-reachability set [10]

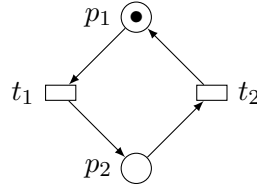

Figure 2. A simple CPN system.

Consider now the PN in Fig. 2 with initial marking $\mathbf{m}_0 = (1, 0)$. Let σ be the infinite sequence $1t_1\frac{1}{2}t_2\frac{1}{3}t_1\frac{1}{4}t_2 \dots \frac{1}{2^i-1}t_1\frac{1}{2^i}t_2 \dots$. Its sequence of visited markings converges toward marking \mathbf{m} defined by: $\mathbf{m} \stackrel{\text{def}}{=} (1 - \log(2), \log(2))$. Here $\vec{\sigma} = \infty t_1 + \infty t_2$.

Let σ be an infinite firing sequence starting from \mathbf{m} whose sequence of visited markings converges toward \mathbf{m}' , one says that \mathbf{m}' is *limit reachable* from \mathbf{m} which is denoted by: $\mathbf{m} \xrightarrow{\sigma}_{\infty} \mathbf{m}'$. Thus in CPN systems, two sets of reachable markings are defined.

Definition 5. Given a CPN system $\langle \mathcal{N}, \mathbf{m}_0 \rangle$,

- Its reachability set $\text{RS}(\mathcal{N}, \mathbf{m}_0)$ is defined by:
 $\text{RS}(\mathcal{N}, \mathbf{m}_0) \stackrel{\text{def}}{=} \{ \mathbf{m} \mid \text{there exists a finite sequence } \mathbf{m}_0 \xrightarrow{\sigma} \mathbf{m} \}.$
- Its lim-reachability set, $\text{lim-RS}(\mathcal{N}, \mathbf{m}_0)$, is defined by:
 $\text{lim-RS}(\mathcal{N}, \mathbf{m}_0) \stackrel{\text{def}}{=} \{ \mathbf{m} \mid \text{there exists an infinite sequence } \mathbf{m}_0 \xrightarrow{\sigma}_{\infty} \mathbf{m} \}.$

RS or lim-RS are convex sets (see Section 3) but not necessarily topologically closed. In Fig. 1, marking $\mathbf{m} = (1, 0, 0, 0)$ belongs to the closure of RS or lim-RS , but it does not belong to these sets. Since an infinite sequence can include null amounts of firings, $\text{RS}(\mathcal{N}, \mathbf{m}_0) \subseteq \text{lim-RS}(\mathcal{N}, \mathbf{m}_0)$. More interestingly, for all $\mathbf{m} \in \text{lim-RS}(\mathcal{N}, \mathbf{m}_0)$, $\text{lim-RS}(\mathcal{N}, \mathbf{m}) \subseteq \text{lim-RS}(\mathcal{N}, \mathbf{m}_0)$ (see later Theorem 22). So there is no need to consider iterations of lim-reachability.

2.2. CPN properties

Here we introduce the standard properties that a modeller wants to check on a net. In the framework of CPNs, every property is defined either w.r.t. to the reachability set or w.r.t. to the lim-reachability set.

Reachability is the main property as it is the core of safeness properties.

Definition 6. (reachability)

Given a CPN system $\langle \mathcal{N}, \mathbf{m}_0 \rangle$ and a marking \mathbf{m} , \mathbf{m} is (lim-)reachable in $\langle \mathcal{N}, \mathbf{m}_0 \rangle$ if $\mathbf{m} \in (\text{lim-})\text{RS}(\mathcal{N}, \mathbf{m}_0)$.

Coverability is a useful property that for instance in PNs can witness violation of mutual exclusion.

Definition 7. (coverability)

Given a CPN system $\langle \mathcal{N}, \mathbf{m}_0 \rangle$ and a marking \mathbf{m} , \mathbf{m} is (lim-)coverable in $\langle \mathcal{N}, \mathbf{m}_0 \rangle$ if there exists $\mathbf{m}' \geq \mathbf{m}$ with $\mathbf{m}' \in (\text{lim-})\text{RS}(\mathcal{N}, \mathbf{m}_0)$.

Boundedness is often related to the resources needed by the system. For CPNs, boundedness and lim-boundedness coincide [15].

Definition 8. (boundedness)

A CPN system $\langle \mathcal{N}, \mathbf{m}_0 \rangle$ is (lim-)bounded if there exists $b \in \mathbb{R}_{\geq 0}$ such that, for all $\mathbf{m} \in (\text{lim-})\text{RS}(\mathcal{N}, \mathbf{m}_0)$ and all $p \in P$, $\mathbf{m}[p] \leq b$.

Deadlock-freeness ensures that a system will never reach a marking where no transition is enabled, i.e. a *dead marking*.

Definition 9. (deadlock-freeness)

A CPN system $\langle \mathcal{N}, \mathbf{m}_0 \rangle$ is (lim-)deadlock-free if for all $\mathbf{m} \in (\text{lim-})\text{RS}(\mathcal{N}, \mathbf{m}_0)$, there exists $t \in T$ such that t is enabled at \mathbf{m} .

The net of Fig. 1 is deadlock-free but not lim-deadlock-free: $\mathbf{m} \stackrel{\text{def}}{=} (0, 1, 0, 0)$ is a *dead* marking which is limit-reachable but not reachable and no reachable marking is dead.

Liveness ensures that whatever the reachable state, any transition will be fireable in some future. So the system never “loses its capacities”.

Definition 10. (liveness)

A CPN system $\langle \mathcal{N}, \mathbf{m}_0 \rangle$ is (lim-)live if for all transition t and for all marking $\mathbf{m} \in (\text{lim-})\text{RS}(\mathcal{N}, \mathbf{m}_0)$ there exists $\mathbf{m}' \in (\text{lim-})\text{RS}(\mathcal{N}, \mathbf{m})$ such that t is enabled at \mathbf{m}' .

The net of Fig. 1 is neither live nor lim-live: once t_1 becomes disabled, it will remain so whatever the finite or infinite firing sequence considered.

A home state is a marking that can be reached whatever the current state. This property can express for instance that recovering from faults is always possible. A net is *reversible* if its initial marking is a home state. Both properties are particular cases of the reachability set inclusion problem.

Definition 11. (reachability set inclusion)

Given CPN systems $\langle \mathcal{N}, \mathbf{m}_0 \rangle$ and $\langle \mathcal{N}', \mathbf{m}'_0 \rangle$ with $P = P'$, $\langle \mathcal{N}, \mathbf{m}_0 \rangle$ is (lim-)reachable included in $\langle \mathcal{N}', \mathbf{m}'_0 \rangle$ if $(\text{lim-})\text{RS}(\mathcal{N}, \mathbf{m}_0) \subseteq (\text{lim-})\text{RS}(\mathcal{N}', \mathbf{m}'_0)$.

A marking \mathbf{m} is a home state if $\text{RS}(\mathcal{N}, \mathbf{m}_0) \subseteq \text{RS}(\mathcal{N}^{-1}, \mathbf{m})$.

When $\mathbf{m} = \mathbf{m}_0$, one says that $\langle \mathcal{N}, \mathbf{m}_0 \rangle$ is reversible.

The following table summarises the results already known about the complexity of the associated decision problems. A net is *consistent* if there exists a vector $\mathbf{v} \in \mathbb{R}_{\geq 0}$ with $\llbracket \mathbf{v} \rrbracket = T$ and $C\mathbf{v} = 0$. No lower bounds have been established.

Table 1. Complexity bounds: previous results

Problems	Upper bounds
(lim-)reachability	in EXPTIME [10] in PTIME for lim-reachability when all transitions are fireable at least once and the net is consistent [15]
(lim-)coverability	no result
(lim-)boundedness	in PTIME when all transitions are fireable at least once [15] (stated without proof)
(lim-)deadlock-freeness	in coNP [14]
(lim-)liveness	in coNP [14]
(lim-)reachability set inclusion	no result

3. Properties characterisations

3.1. Preliminary results about reachability and firing sequences

Most of the results of this subsection are generalisations of results given in [15, 10].

The following lemma is an almost immediate consequence of the firing definition of CPNs. It entails the convexity of the (lim-)reachability set. In this lemma depending on the sequences $\rightarrow_{(\infty)}$ denotes either \rightarrow or \rightarrow_{∞} .

Lemma 12. Given a CPN system $\langle \mathcal{N}, \mathbf{m}_0 \rangle$, (finite or infinite) sequences $\sigma, \sigma_1, \sigma_2$ markings $\mathbf{m}, \mathbf{m}', \mathbf{m}_1, \mathbf{m}_2, \mathbf{m}'_1, \mathbf{m}'_2$ and $\alpha, \alpha_1, \alpha_2 \in \mathbb{R}_{>0}$:

(0) $\mathbf{m}_1 \xrightarrow{\sigma} \mathbf{m}'_1$ and $\mathbf{m}_1 \leq \mathbf{m}_2$ implies $\mathbf{m}_2 \xrightarrow{\sigma} \mathbf{m}'_2$ with $\mathbf{m}'_1 \leq \mathbf{m}'_2$

(1) $\mathbf{m} \xrightarrow{\sigma}_{(\infty)} \mathbf{m}$ iff $\alpha \mathbf{m} \xrightarrow{\alpha \sigma}_{(\infty)} \alpha \mathbf{m}'$

- (2) $m \xrightarrow{\sigma}_{\infty}$ iff $\alpha m \xrightarrow{\alpha\sigma}_{\infty}$
(3) $m_1 \xrightarrow{\sigma_1}_{(\infty)} m'_1$ and $m_2 \xrightarrow{\sigma_2}_{(\infty)} m'_2$ implies $m_1 + m_2 \xrightarrow{\sigma_1 + \sigma_2}_{(\infty)} m'_1 + m'_2$
(4) $m_1 \xrightarrow{\sigma_1}_{\infty}$ and $m_2 \xrightarrow{\sigma_2}_{\infty}$ implies $m_1 + m_2 \xrightarrow{\sigma_1 + \sigma_2}_{\infty}$
(5) $m_1 \xrightarrow{\alpha_1\sigma}_{(\infty)} m'_1$ and $m_2 \xrightarrow{\alpha_2\sigma}_{(\infty)} m'_2$ implies $m_1 + m_2 \xrightarrow{(\alpha_1 + \alpha_2)\sigma}_{(\infty)} m'_1 + m'_2$
(6) $m_1 \xrightarrow{\alpha_1\sigma}_{\infty}$ and $m_2 \xrightarrow{\alpha_2\sigma}_{\infty}$ implies $m_1 + m_2 \xrightarrow{(\alpha_1 + \alpha_2)\sigma}_{\infty}$

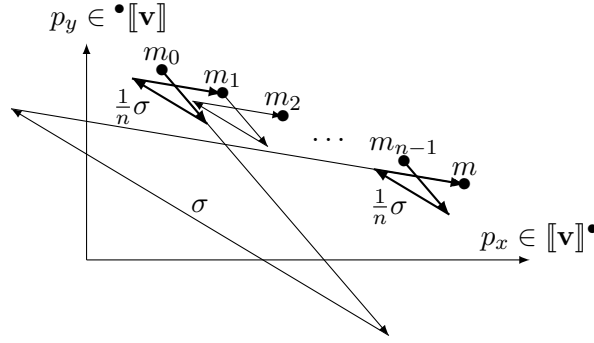

The two next lemmas constitute a first step for the characterisation of reachability since they provide sufficient conditions for reachability and lim-reachability in particular cases. Let us explain why the three items of the next lemma ensure reachability of m from m_0 . The first item is a necessary condition for reachability since the Parikh image \mathbf{v} of a reachability sequence σ must satisfy this equation (see [7] for another application of this condition). The figure above shows the effect of an arbitrary firing sequence σ built from such a vector v on the marking of two places: the vertical axis corresponds to a place $p_y \in \bullet[[\mathbf{v}]]$ while the horizontal axis corresponds to a place $p_x \in [[\mathbf{v}]]\bullet$. As shown on the figure after the firing of the first transition of σ the marking of p_y may be negative and before the firing of the last transition of σ the marking of p_x may be negative. However for a n enough large due to the second item, $\frac{1}{n}\sigma$ may be fired from m_0 and due to the third item $\frac{1}{n}\sigma^{-1}$ may be fired from m (see the figure). One gets the conclusion using the convexity of the set of nonnegative markings.

Lemma 13. Let $\langle \mathcal{N}, m_0 \rangle$ be a CPN system, m be a marking and $\mathbf{v} \in \mathbb{R}_{\geq 0}^T$ that fulfill:

- $m = m_0 + C\mathbf{v}$;
- $\forall p \in \bullet[[\mathbf{v}]] m_0[p] > 0$;
- $\forall p \in [[\mathbf{v}]]\bullet m[p] > 0$.

Then there exists a finite sequence σ such that $m_0 \xrightarrow{\sigma} m$ and $\vec{\sigma} = \mathbf{v}$.

Proof. Define $\alpha_1 \stackrel{\text{def}}{=} \min(\frac{m_0[p]}{\sum_{t \in [[\mathbf{v}]]} \text{Pre}[p,t]\mathbf{v}[t]} \mid p \in \bullet[[\mathbf{v}]])$

and $\alpha_2 \stackrel{\text{def}}{=} \min(\frac{m[p]}{\sum_{t \in [[\mathbf{v}]]} \text{Post}[p,t]\mathbf{v}[t]} \mid p \in [[\mathbf{v}]]\bullet)$ with the convention that $\alpha_1 \stackrel{\text{def}}{=} 1$ (resp. $\alpha_2 \stackrel{\text{def}}{=} 1$) if $\bullet[[\mathbf{v}]]$ (resp. $[[\mathbf{v}]]\bullet$) is empty.

Due to the second and the third hypotheses α_1 and α_2 are positive.

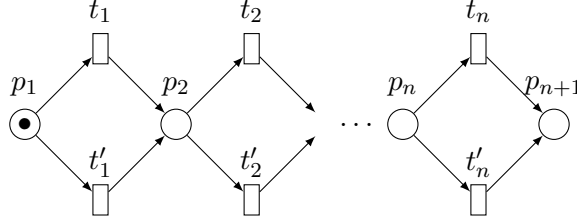

Figure 3. A CPN system with an exponentially sized firing set.

Let $n \stackrel{\text{def}}{=} \max(\lceil \frac{1}{\min(\alpha_1, \alpha_2)} \rceil, 2)$.

Denote $\llbracket v \rrbracket \stackrel{\text{def}}{=} \{t_1, \dots, t_k\}$ and define $\sigma' \stackrel{\text{def}}{=} \frac{\mathbf{v}[t_1]}{n} t_1 \dots \frac{\mathbf{v}[t_k]}{n} t_k$ and $\sigma \stackrel{\text{def}}{=} \sigma'^m$.

We claim that σ is the required firing sequence.

Let us denote $\mathbf{m}_i \stackrel{\text{def}}{=} \mathbf{m}_0 + \frac{i}{n} C\mathbf{v}$. Thus $\mathbf{m} = \mathbf{m}_n$.

By definition of α_1 and n , in \mathcal{N} $\mathbf{m}_0 \xrightarrow{\sigma'} \mathbf{m}_1$ and by definition of α_2 , $\mathbf{m}_n \xrightarrow{\sigma'^{-1}} \mathbf{m}_{n-1}$ in \mathcal{N}^{-1} . So in \mathcal{N} $\mathbf{m}_{n-1} \xrightarrow{\sigma'} \mathbf{m}_n$.

Let $1 < i < n - 1$.

Using lemma 12, $\frac{n-1-i}{n-1} \mathbf{m}_0 \xrightarrow{\frac{n-1-i}{n-1} \sigma'} \frac{n-1-i}{n-1} \mathbf{m}_1$ and $\frac{i}{n-1} \mathbf{m}_{n-1} \xrightarrow{\frac{i}{n-1} \sigma'} \frac{i}{n-1} \mathbf{m}_n$.

Using lemma 12 again and summing, one gets: $\mathbf{m}_i \xrightarrow{\sigma'} \mathbf{m}_{i+1}$. ■

Based on the previous lemma, we develop a sufficient condition for lim-reachability. The main ideas are: (1) to build an infinite firing sequence of the form $\mathbf{m}_0 \rightarrow \frac{1}{2} \mathbf{m}_0 + \frac{1}{2} \mathbf{m} \rightarrow \frac{1}{4} \mathbf{m}_0 + \frac{3}{4} \mathbf{m} \rightarrow \dots$ and (2) as a fraction of \mathbf{m}_0 occurs in every intermediate marking to merge the two positivity requirements on a single requirement for \mathbf{m}_0 .

Lemma 14. Let $\langle \mathcal{N}, \mathbf{m}_0 \rangle$ be a CPN system, \mathbf{m} be a marking and $\mathbf{v} \in \mathbb{R}_{\geq 0}^T$ that fulfill:

- $\mathbf{m} = \mathbf{m}_0 + C\mathbf{v}$;
- $\forall p \in \bullet \llbracket \mathbf{v} \rrbracket \bullet \mathbf{m}_0[p] > 0$.

Then there exists an infinite sequence σ such that $\mathbf{m}_0 \xrightarrow{\sigma} \infty \mathbf{m}$ and $\vec{\sigma} = \mathbf{v}$.

Proof. Let \mathbf{m}_i be inductively defined by $\mathbf{m}_{i+1} = \frac{1}{2} \mathbf{m}_i + \frac{1}{2} \mathbf{m}$. and for $i \geq 1$, let $\mathbf{v}_i = \frac{1}{2^i} \mathbf{v}$ (thus $\llbracket \mathbf{v}_i \rrbracket = \llbracket \mathbf{v} \rrbracket$). Observe that $\mathbf{m}_i = \frac{1}{2^i} \mathbf{m}_0 + (1 - \frac{1}{2^i}) \mathbf{m}$. So:

- $\mathbf{m}_{i+1} = \mathbf{m}_i + C\mathbf{v}_i$;
- $\forall p \in \bullet \llbracket \mathbf{v}_i \rrbracket \bullet \mathbf{m}_i[p] > 0$ and $\mathbf{m}_{i+1}[p] > 0$.

Applying lemma 13, for all $i \geq 1$ there exists σ_i such that $\mathbf{m}_i \xrightarrow{\sigma_i} \mathbf{m}_{i+1}$. Since $\lim_{i \rightarrow \infty} \mathbf{m}_i = \mathbf{m}$, the sequence $\sigma = \sigma_1 \sigma_2 \dots$ is the required sequence. ■

The key concept in order to get characterisation of properties, is the notion of *firing set* of a CPN system [10].

Definition 15. Let $\langle \mathcal{N}, \mathbf{m}_0 \rangle$ be a CPN system. Then its firing set $FS(\mathcal{N}, \mathbf{m}_0) \subseteq 2^T$ is defined by:

$$FS(\mathcal{N}, \mathbf{m}_0) \stackrel{\text{def}}{=} \{ \llbracket \vec{\sigma} \rrbracket \mid \mathbf{m}_0 \xrightarrow{\sigma} \}$$

Due to the empty sequence, $\emptyset \in FS(\mathcal{N}, \mathbf{m}_0)$. The size of a firing set may be exponential w.r.t. the number of transitions of the net. For example, consider the CPN system of Fig. 3. Its firing set is:

$$\{ T' \mid \forall 1 \leq j < i \leq n \{t_i, t'_i\} \cap T' \neq \emptyset \Rightarrow \{t_j, t'_j\} \cap T' \neq \emptyset \}$$

Thus its size is at least $2^{\frac{|T|}{2}}$.

The next two lemmas establish elementary properties of the firing set and lead to new notions.

Lemma 16. Let \mathcal{N} be a CPN and \mathbf{m}, \mathbf{m}' be two markings such that $\llbracket \mathbf{m} \rrbracket = \llbracket \mathbf{m}' \rrbracket$. Then $FS(\mathcal{N}, \mathbf{m}) = FS(\mathcal{N}, \mathbf{m}')$.

Proof. Since $\llbracket \mathbf{m} \rrbracket = \llbracket \mathbf{m}' \rrbracket$, there exists $\alpha > 0$ such that $\alpha \mathbf{m} \leq \mathbf{m}'$. Let $\mathbf{m} \xrightarrow{\sigma}$. Using lemma 12 $\alpha \mathbf{m} \xrightarrow{\alpha \sigma}$. Since $\alpha \mathbf{m} \leq \mathbf{m}'$, $\mathbf{m}' \xrightarrow{\alpha \sigma}$. Thus $FS(\mathcal{N}, \mathbf{m}) \subseteq FS(\mathcal{N}, \mathbf{m}')$. By symmetry, $FS(\mathcal{N}, \mathbf{m}) = FS(\mathcal{N}, \mathbf{m}')$. ■

So given $P' \subseteq P$, without ambiguity we define $FS(\mathcal{N}, P')$ by:

$$FS(\mathcal{N}, P') \stackrel{\text{def}}{=} FS(\mathcal{N}, \mathbf{m}) \text{ for any } \mathbf{m} \text{ such that } P' = \llbracket \mathbf{m} \rrbracket$$

Lemma 17. Let $\langle \mathcal{N}, \mathbf{m}_0 \rangle$ be a CPN system. Then $FS(\mathcal{N}, \mathbf{m}_0)$ is closed by union.

Proof. Let $\mathbf{m}_0 \xrightarrow{\sigma}$ and $\mathbf{m}_0 \xrightarrow{\sigma'}$. Then using three times lemma 12, $0.5\mathbf{m}_0 \xrightarrow{0.5\sigma}$, $0.5\mathbf{m}_0 \xrightarrow{0.5\sigma'}$ and $\mathbf{m}_0 \xrightarrow{0.5\sigma+0.5\sigma'}$. Since $\llbracket 0.5\sigma + 0.5\sigma' \rrbracket = \llbracket \vec{\sigma} \rrbracket \cup \llbracket \vec{\sigma}' \rrbracket$, the conclusion follows. ■

Notation. We denote $\max FS(\mathcal{N}, \mathbf{m}_0)$ the maximal set of $FS(\mathcal{N}, \mathbf{m}_0)$ that is the union of all members of $FS(\mathcal{N}, \mathbf{m}_0)$.

The next proposition is a structural characterisation for a subset of transitions to belong to the firing set. In addition, it shows that in the positive case, a “useful” corresponding sequence always exists and furthermore one may build this sequence in polynomial time. In order to improve the understanding of the proof, we first informally why the condition is sufficient and how to build the sequence. Assume that $\mathcal{N}_{T'}$ has no empty siphon in \mathbf{m}_0 . So there is at least one initially fireable transition. Otherwise for all transition $t \in T'$ there would be a place p_t with $\mathbf{m}_0(p_t) = 0$ and so the union of these places would be an empty siphon in \mathbf{m}_0 . Let T_1 be the set of initially fireable transitions. Then one can fire a small amount of each transition of T_1 leading to a marking \mathbf{m}_1 so that all marked places in \mathbf{m}_0 remain marked in \mathbf{m}_1 . Then either $T_1 = T'$ or by a similar argument there is at least a transition of $T' \setminus T_1$ fireable in \mathbf{m}_1 . Let us illustrate it on the CPN system of Figure 1(a) with $T' = T$. Initially only t_1 is fireable, so one fires it with any amount less than 1, say $0.5t_1$ for instance. Thus $\mathbf{m}_1 = (0.5, 0.5, 1, 0)$ and in \mathbf{m}_1 , t_2 is fireable, one fires $0.25t_2$ in order that p_3 remains marked in $\mathbf{m}_2 = (0.5, 0.5, 0.5, 0.25)$. Then one fires $0.2t_3$ leading to $\mathbf{m}_3 = (0.5, 0.5, 0.7, 0.05)$. Observe that once a place is marked, the selected sequence never unmarks it.

Proposition 18. Let $\langle \mathcal{N}, \mathbf{m}_0 \rangle$ be a CPN system and T' be a subset of transitions. Then:

$$T' \in FS(\mathcal{N}, \mathbf{m}_0) \text{ iff } \mathcal{N}_{T'} \text{ has no empty siphon in } \mathbf{m}_0.$$

Furthermore if $T' \in FS(\mathcal{N}, \mathbf{m}_0)$ then there exists $\sigma = \alpha_1 t_1 \dots \alpha_k t_k$ with $\alpha_i > 0$ for all i , $T' = \{t_1, \dots, t_k\}$ and a marking \mathbf{m} such that:

- $\mathbf{m}_0 \xrightarrow{\sigma} \mathbf{m}$;
- for all place p , $\mathbf{m}(p) > 0$ iff $\mathbf{m}_0(p) > 0$ or $p \in \bullet T' \bullet$.

Proof.

Necessity. Suppose $\mathcal{N}_{T'}$ contains an empty siphon Σ in \mathbf{m}_0 . Then none of the transitions belonging Σ^\bullet can be fired in the future. Since $\mathcal{N}_{T'}$ does not contain isolated places $\Sigma^\bullet (= \bullet \Sigma^\bullet) \neq \emptyset$ and so $T' \notin FS(\mathcal{N}, \mathbf{m}_0)$.

Sufficiency. Suppose that $\mathcal{N}_{T'}$ has no empty siphon in \mathbf{m}_0 . We build by induction the sequence σ of the proposition. More precisely, we inductively prove for increasing values of i that:

- for every $0 < j < i$ there exists a non empty set of transitions $T_j \subseteq T'$ that fulfill for all $j \neq j'$, $T_j \cap T_{j'} = \emptyset$;
- for every $j \leq i$ there exists a marking \mathbf{m}_j with $\mathbf{m}_j(p) > 0$ iff $\mathbf{m}_0(p) > 0$ or $p \in \bullet T_k \bullet$ for some $k < j$;
- for every $j < i$ there exists a sequence $\sigma_j = \alpha_{j,1} t_{j,1} \dots \alpha_{j,k_j} t_{j,k_j}$ with $T_j = \{t_{j,1} \dots t_{j,k_j}\}$ and $\mathbf{m}_j \xrightarrow{\sigma_j} \mathbf{m}_{j+1}$.

There is nothing to prove for the basis case $i = 0$.

Suppose that the assertion holds until i . If $T' = T_1 \cup \dots \cup T_{i-1}$ then we are done.

Otherwise define $T'' = T' \setminus (T_1 \cup \dots \cup T_{i-1})$ and $T_i = \{t \text{ enabled in } \mathbf{m}_i \mid t \in T''\}$. We claim that T_i is not empty. Otherwise for all $t \in T''$, there exists an empty place p_t in \mathbf{m}_i . Due to the inductive hypothesis, $\mathbf{m}_0(p_t) = 0$ and $\bullet p_t \cap (T_1 \cup \dots \cup T_{i-1}) = \emptyset$. So the union of places p_t is an empty siphon of $\langle \mathcal{N}_{T'}, \mathbf{m}_0 \rangle$ which contradicts our hypothesis.

Let us denote $T_i = \{t_{i,1} \dots t_{i,k_i}\}$. Define $\alpha = \min(\frac{\mathbf{m}_i(p)}{2k_i} \mid p \in \bullet T_i)$ with the convention that $\alpha = 1$ if $\bullet T_i = \emptyset$. The sequence $\sigma_i = \alpha t_{i,1} \dots \alpha t_{i,k_i}$ is fireable from \mathbf{m}_i and leads to a marking \mathbf{m}_{i+1} fulfilling the inductive hypothesis.

Since T'' is finite the procedure terminates. ■

We include the complexity result below since its proof relies in a straightforward manner on the sufficiency proof of the previous proposition.

Corollary 19. Let $\langle \mathcal{N}, \mathbf{m}_0 \rangle$ be a CPN system and T' be a subset of transitions. Then algorithm 1 checks in polynomial time whether $T' \in FS(\mathcal{N}, \mathbf{m}_0)$ and in the negative case returns the maximal firing set included in T' (when called with $T = T'$, it returns $\max FS(\mathcal{N}, \mathbf{m}_0)$).

3.2. Characterisation of reachability, coverability and boundedness

In [10] a characterisation of reachability was presented. The theorem below is an alternative characterisation that only relies on the state equation and firing sets.

Algorithm 1: Decision algorithm for membership of $FS(\mathcal{N}, \mathbf{m}_0)$

Fireable($\langle \mathcal{N}, \mathbf{m}_0 \rangle, T'$): status
Input: a CPN system $\langle \mathcal{N}, \mathbf{m}_0 \rangle$, a subset of transitions T'
Output: the membership status of T' w.r.t. $FS(\mathcal{N}, \mathbf{m}_0)$
Output: in the negative case the maximal firing set included in T'
Data: *new*: boolean; P' : subset of places; T'' : subset of transitions

- 1 $T'' \leftarrow \emptyset$; $P' \leftarrow \llbracket \mathbf{m}_0 \rrbracket$
- 2 **while** $T'' \neq T'$ **do**
- 3 $new \leftarrow \text{false}$
- 4 **for** $t \in T' \setminus T''$ **do**
- 5 **if** $\bullet t \subseteq P'$ **then** $T'' \leftarrow T'' \cup \{t\}$; $P' \leftarrow P' \cup t^\bullet$; $new \leftarrow \text{true}$
- 6 **end**
- 7 **if not** new **then return** (false, T'')
- 8 **end**
- 9 **return true**

Theorem 20. Let $\langle \mathcal{N}, \mathbf{m}_0 \rangle$ be a CPN system and \mathbf{m} be a marking. Then $\mathbf{m} \in RS(\mathcal{N}, \mathbf{m}_0)$ iff there exists $\mathbf{v} \in \mathbb{R}_{\geq 0}^T$ such that:

1. $\mathbf{m} = \mathbf{m}_0 + C\mathbf{v}$
2. $\llbracket \mathbf{v} \rrbracket \in FS(\mathcal{N}, \mathbf{m}_0)$
3. $\llbracket \mathbf{v} \rrbracket \in FS(\mathcal{N}^{-1}, \mathbf{m})$

Proof.

Necessity. Let $\mathbf{m} \in RS(\mathcal{N}, \mathbf{m}_0)$. So there exists a finite firing sequence σ such that $\mathbf{m}_0 \xrightarrow{\sigma} \mathbf{m}$. Let $\mathbf{v} = \vec{\sigma}$, then $\mathbf{m} = \mathbf{m}_0 + C\mathbf{v}$.

Since σ is fireable from \mathbf{m}_0 in \mathcal{N} , $\llbracket \mathbf{v} \rrbracket \in FS(\mathcal{N}, \mathbf{m}_0)$. In \mathcal{N}^{-1} , $\mathbf{m} \xrightarrow{\sigma^{-1}} \mathbf{m}_0$. Since $\mathbf{v} = \overrightarrow{\sigma^{-1}}$, $\llbracket \mathbf{v} \rrbracket \in FS(\mathcal{N}^{-1}, \mathbf{m})$.

Sufficiency. Since $\llbracket \mathbf{v} \rrbracket \in FS(\mathcal{N}, \mathbf{m}_0)$, using Proposition 18 and Lemma 12 there exists a sequence σ_1 such that $\llbracket \mathbf{v} \rrbracket = \llbracket \vec{\sigma}_1 \rrbracket$, for all $0 < \alpha_1 \leq 1$, $\mathbf{m}_0 \xrightarrow{\alpha_1 \sigma_1} \mathbf{m}_1$ with $\mathbf{m}_1(p) > 0$ for $p \in \bullet \llbracket \mathbf{v} \rrbracket^\bullet$.

Since $\llbracket \mathbf{v} \rrbracket \in FS(\mathcal{N}^{-1}, \mathbf{m})$, using Proposition 18 and Lemma 12 there exists a sequence σ_2 such that $\llbracket \mathbf{v} \rrbracket = \llbracket \vec{\sigma}_2 \rrbracket$, for all $0 < \alpha_2 \leq 1$, $\mathbf{m} \xrightarrow{\alpha_2 \sigma_2} \mathbf{m}_2$ in \mathcal{N}^{-1} with $\mathbf{m}_2(p) > 0$ for $p \in \bullet \llbracket \mathbf{v} \rrbracket^\bullet$.

Choose α_1 and α_2 enough small such that the vector $\mathbf{v}' = \mathbf{v} - \alpha_1 \vec{\sigma}_1 - \alpha_2 \vec{\sigma}_2$ is nonnegative and $\llbracket \mathbf{v}' \rrbracket = \llbracket \mathbf{v} \rrbracket$. This is possible since $\llbracket \mathbf{v} \rrbracket = \llbracket \vec{\sigma}_1 \rrbracket = \llbracket \vec{\sigma}_2 \rrbracket$.

Since $\mathbf{m}_2 = \mathbf{m}_1 + C\mathbf{v}'$ and $\mathbf{m}_1, \mathbf{m}_2$ fulfill the hypotheses of Lemma 13, there exists a sequence σ_3 such that $\mathbf{v}' = \vec{\sigma}_3$ and $\mathbf{m}_1 \xrightarrow{\sigma_3} \mathbf{m}_2$.

Let $\sigma = (\alpha_1 \sigma_1) \sigma_3 (\alpha_2 \sigma_2)^{-1}$ then $\mathbf{m}_0 \xrightarrow{\sigma} \mathbf{m}$. ■

Example. Let us illustrate the reachability characterisation on the CPN of Figure 1(a). Let $\mathbf{m}_0 = (1, 0, 1, 0)$ and $\mathbf{m} = (0, 1, 0, 0)$, the single solution of the linear equation system is $\vec{t}_1 + \vec{t}_2 + \vec{t}_3$. On the other hand, $FS(\mathcal{N}, \mathbf{m}_0) = \{\emptyset, \{t_1\}, \{t_1, t_2\}, \{t_1, t_2, t_3\}\}$. So the second condition is satisfied. However $FS(\mathcal{N}^{-1}, \mathbf{m}) = \{\emptyset, \{t_1\}\}$. So the third condition is not satisfied and \mathbf{m} is not reachable from \mathbf{m}_0 .

The following characterisation has been stated in [10]. We include the proof here since in that paper, the proof of necessity was not developed.

Theorem 21. Let $\langle \mathcal{N}, \mathbf{m}_0 \rangle$ be a CPN system and \mathbf{m} be a marking. Then $\mathbf{m} \in \text{lim-RS}(\mathcal{N}, \mathbf{m}_0)$ iff there exists $\mathbf{v} \in \mathbb{R}_{\geq 0}^T$ such that:

1. $\mathbf{m} = \mathbf{m}_0 + \mathbf{C}\mathbf{v}$
2. $\llbracket \mathbf{v} \rrbracket \in FS(\mathcal{N}, \mathbf{m}_0)$

Proof.

Necessity. Let $\mathbf{m} \in \text{lim-RS}(\mathcal{N}, \mathbf{m}_0)$. So there exists a firing sequence $\sigma = \alpha_1 t_1 \dots \alpha_n t_n \dots$ such that $\mathbf{m} = \lim_{n \rightarrow \infty} \mathbf{m}_n$, where $\mathbf{m}_n \xrightarrow{\alpha_{n+1} t_{n+1}} \mathbf{m}_{n+1}$.

Thus there exists $B \in \mathbb{N}$ such that for all $p \in P$ and all $n \in \mathbb{N}$, $\mathbf{m}_n[p] \leq B$.

Let $T' \stackrel{\text{def}}{=} \{t \mid \exists i \in \mathbb{N} t = t_i\}$. There exists n_0 such that $T' = \{t \mid \exists i \leq n_0 t = t_i\}$ and so $T' \in FS(\mathcal{N}, \mathbf{m}_0)$.

Let $\alpha \in \mathbb{Q}_{>0}$ such that $\alpha \leq \min(\sum_{i \leq n_0, t_i=t} \alpha_i \mid t \in T')$.

Let us define LP_n an existential linear program where $\mathbf{v} \in \mathbb{R}^T$ is the vector of variables by:

1. $\mathbf{m}_n - \mathbf{m}_0 = \mathbf{C}\mathbf{v}$
2. $\forall t \in T' \mathbf{v}[t] \geq \alpha$
3. $\forall t \in T \setminus T' \mathbf{v}[t] = 0$

Due to the existence of the firing sequence σ , for all $n \geq n_0$ LP_n admits a solution. Using linear programming theory (see [13]), since $\mathbf{m}_n[p] \leq B$ for all n and all p , there exists B' such that for all $n \geq n_0$, LP_n admits a solution \mathbf{v}_n whose items are bounded by B' .

So the sequence $\{\mathbf{v}_n\}_{n \geq n_0}$ admits a subsequence that converges to some \mathbf{v} . By continuity, \mathbf{v} fulfills $\mathbf{m} - \mathbf{m}_0 = \mathbf{C}\mathbf{v}$, $\forall t \in T' \mathbf{v}[t] \geq \alpha$ and $\forall t \in T \setminus T' \mathbf{v}[t] = 0$.

So $\llbracket \mathbf{v} \rrbracket = T'$ and \mathbf{v} is the desired vector.

Sufficiency. Since $\llbracket \mathbf{v} \rrbracket \in FS(\mathcal{N}, \mathbf{m}_0)$, using Proposition 18 and Lemma 12 there exists a sequence σ_1 such that $\llbracket \mathbf{v} \rrbracket = \llbracket \vec{\sigma}_1 \rrbracket$, for all $0 < \alpha_1 \leq 1$, $\mathbf{m}_0 \xrightarrow{\alpha_1 \sigma_1} \mathbf{m}_1$ with $\mathbf{m}_1(p) > 0$ for $p \in \bullet \llbracket \mathbf{v} \rrbracket$.

Choose α_1 enough small such that the vector $\mathbf{v}' = \mathbf{v} - \alpha_1 \vec{\sigma}_1$ is nonnegative and $\llbracket \mathbf{v}' \rrbracket = \llbracket \mathbf{v} \rrbracket$. This is possible since $\llbracket \mathbf{v} \rrbracket = \llbracket \vec{\sigma}_1 \rrbracket$.

Since $\mathbf{m} = \mathbf{m}_1 + \mathbf{C}\mathbf{v}'$ and \mathbf{m}_1 fulfills the hypotheses of lemma 14, there exists an infinite sequence σ_2 such that $\mathbf{v}' = \vec{\sigma}_2$ and $\mathbf{m}_1 \xrightarrow{\sigma_2} \mathbf{m}$.

Let $\sigma = (\alpha_1 \sigma_1) \sigma_2$ then $\mathbf{m}_0 \xrightarrow{\sigma} \mathbf{m}$. ■

Example. Let us illustrate the lim-reachability characterisation on the CPN of Figure 1(a). Let $\mathbf{m}_0 = (1, 0, 1, 0)$ and $\mathbf{m} = (0, 1, 0, 0)$. Since the third condition of reachability is not required for lim-reachability, \mathbf{m} is reachable from \mathbf{m}_0 . Let $\mathbf{m}' = (1, 0, 0, 0)$, the single solution of the linear equation system is $\vec{t}_2 + \vec{t}_3$ and $\{t_2, t_3\}$ does not belong to $FS(\mathcal{N}, \mathbf{m}_0)$. So \mathbf{m}' is not lim-reachable from \mathbf{m}_0 .

Using the previous theorem, we develop a short proof that iterating the lim-reachability is useless.

Theorem 22. Let $\langle \mathcal{N}, \mathbf{m}_0 \rangle$ be a CPN system.

Then for all $\mathbf{m} \in \text{lim-RS}(\mathcal{N}, \mathbf{m}_0)$, $\text{lim-RS}(\mathcal{N}, \mathbf{m}) \subseteq \text{lim-RS}(\mathcal{N}, \mathbf{m}_0)$.

Proof. Let $\mathbf{m}' \in \text{lim-RS}(\mathcal{N}, \mathbf{m})$. Due to Theorem 21, there exists $\mathbf{v}, \mathbf{v}' \in \mathbb{R}_{\geq 0}^T$ such that:

1. $\mathbf{m} = \mathbf{m}_0 + \mathbf{C}\mathbf{v}$ and $\mathbf{m}' = \mathbf{m} + \mathbf{C}\mathbf{v}'$
2. $\llbracket \mathbf{v} \rrbracket \in FS(\mathcal{N}, \mathbf{m}_0)$ and $\llbracket \mathbf{v}' \rrbracket \in FS(\mathcal{N}, \mathbf{m})$

Thus $\mathbf{m}' = \mathbf{m}_0 + \mathbf{C}(\mathbf{v} + \mathbf{v}')$.

Due to proposition 18, since $\llbracket \mathbf{v} \rrbracket \in FS(\mathcal{N}, \mathbf{m}_0)$ there exists a sequence σ and a marking \mathbf{m}^* such that $\mathbf{m}_0 \xrightarrow{\sigma} \mathbf{m}^*$ and $\llbracket \vec{\sigma} \rrbracket = \llbracket \mathbf{v} \rrbracket$ and $\llbracket \mathbf{m}^* \rrbracket = \llbracket \mathbf{m}_0 \rrbracket \cup \bullet \llbracket \mathbf{v} \rrbracket \bullet$.

Since $\mathbf{m} = \mathbf{m}_0 + \mathbf{C}\mathbf{v}$, $\llbracket \mathbf{m} \rrbracket \subseteq \llbracket \mathbf{m}^* \rrbracket$ and so $\llbracket \mathbf{v}' \rrbracket \in FS(\mathcal{N}, \mathbf{m}^*)$. Hence $\llbracket \mathbf{v} + \mathbf{v}' \rrbracket = \llbracket \mathbf{v} \rrbracket \cup \llbracket \mathbf{v}' \rrbracket \in FS(\mathcal{N}, \mathbf{m}_0)$. Using in the other direction the characterization of Theorem 21 with $\mathbf{v} + \mathbf{v}'$, one gets $\mathbf{m}' \in \text{lim-RS}(\mathcal{N}, \mathbf{m}_0)$. ■

The two following theorems related to coverability are direct consequences of Theorems 20 and 21 and the definition of (lim-)coverability.

Theorem 23. Let $\langle \mathcal{N}, \mathbf{m}_0 \rangle$ be a CPN system and \mathbf{m} be a marking. Then \mathbf{m} is coverable in $\langle \mathcal{N}, \mathbf{m}_0 \rangle$ iff there exists $\mathbf{v} \in \mathbb{R}_{\geq 0}^T$ and $\mathbf{w} \in \mathbb{R}_{\geq 0}^P$ such that:

1. $\mathbf{m} + \mathbf{w} = \mathbf{m}_0 + \mathbf{C}\mathbf{v}$
2. $\llbracket \mathbf{v} \rrbracket \in FS(\mathcal{N}, \mathbf{m}_0)$
3. $\llbracket \mathbf{v} \rrbracket \in FS(\mathcal{N}^{-1}, \mathbf{m} + \mathbf{w})$

Theorem 24. Let $\langle \mathcal{N}, \mathbf{m}_0 \rangle$ be a CPN system and \mathbf{m} be a marking. Then \mathbf{m} is lim-coverable in $\langle \mathcal{N}, \mathbf{m}_0 \rangle$ iff there exists $\mathbf{v} \in \mathbb{R}_{\geq 0}^T$ and $\mathbf{w} \in \mathbb{R}_{\geq 0}^P$ such that:

1. $\mathbf{m} + \mathbf{w} = \mathbf{m}_0 + \mathbf{C}\mathbf{v}$
2. $\llbracket \mathbf{v} \rrbracket \in FS(\mathcal{N}, \mathbf{m}_0)$

We present below the first characterisation of boundedness for CPN systems.

Theorem 25. Given a CPN system $\langle \mathcal{N}, \mathbf{m}_0 \rangle$. Then $\langle \mathcal{N}, \mathbf{m}_0 \rangle$ is unbounded iff:

There exists $\mathbf{v} \in \mathbb{R}_{\geq 0}^T$ such that $\mathbf{C}\mathbf{v} \succeq \mathbf{0}$ and $\llbracket \mathbf{v} \rrbracket \subseteq \text{maxFS}(\mathcal{N}, \mathbf{m}_0)$.

Proof.

Sufficiency. Assume there exists $\mathbf{v} \in \mathbb{R}_{\geq 0}^T$ such that $\mathbf{C}\mathbf{v} \succeq \mathbf{0}$ and $\llbracket \mathbf{v} \rrbracket \subseteq \text{maxFS}(\mathcal{N}, \mathbf{m}_0)$. Denote $T' \stackrel{\text{def}}{=} \text{maxFS}(\mathcal{N}, \mathbf{m}_0)$. Using proposition 18, there exists $\mathbf{m}_1 \in RS(\mathcal{N}, \mathbf{m}_0)$ such that for all $p \in \bullet T' \bullet$, $\mathbf{m}_1(p) > 0$. Define $\mathbf{m}_2 \stackrel{\text{def}}{=} \mathbf{m}_1 + \mathbf{C}\mathbf{v}$, thus $\mathbf{m}_2 \succeq \mathbf{m}_1$. Since $\llbracket \mathbf{v} \rrbracket \subseteq T'$, \mathbf{m}_1 and \mathbf{m}_2 fulfill the hypotheses of lemma 13. Applying it, yields a firing sequence $\mathbf{m}_1 \xrightarrow{\sigma} \mathbf{m}_2$. Iterating this sequence establishes the unboundedness of $\langle \mathcal{N}, \mathbf{m}_0 \rangle$.

Necessity. Assume $\langle \mathcal{N}, \mathbf{m}_0 \rangle$ is unbounded. Then there exists $p \in P$ and a family of firing sequences $\{\sigma_n\}_{n \in \mathbb{N}}$ such that $\mathbf{m}_0 \xrightarrow{\sigma_n} \mathbf{m}_n$ and $\mathbf{m}_n(p) \geq n$. Since $\{\llbracket \vec{\sigma}_n \rrbracket\}_{n \in \mathbb{N}}$ is finite by extracting a subsequence w.l.o.g. we can assume that all these sequences have the same support, say $T' \subseteq \max\text{FS}(\mathcal{N}, \mathbf{m}_0)$. Let $\mathbf{v}_n \stackrel{\text{def}}{=} C \vec{\sigma}_n$. Define $\mathbf{w}_n = \frac{\mathbf{v}_n}{\|\mathbf{v}_n\|_1}$. Since $\{\mathbf{w}_n\}_{n \in \mathbb{N}}$ belongs to a compact set, there exists a convergent subsequence $\{\mathbf{w}_{\alpha(n)}\}_{n \in \mathbb{N}}$. Denote \mathbf{w} its limit. Since $\|\mathbf{w}\|_1 = 1$, \mathbf{w} is non null. We claim that \mathbf{w} is a nonnegative vector. Since $\mathbf{m}_n(p) \geq n$, $\|\mathbf{v}_n\|_1 \geq \mathbf{v}_n[p] \geq n - \mathbf{m}_0[p]$. On the other hand, for all $p' \in P$, $\mathbf{w}_n[p'] \geq \frac{-\mathbf{m}_0[p']}{\|\mathbf{v}_n\|_1}$. Combining the two inequalities, for $n > \mathbf{m}_0[p]$, $\mathbf{w}_n[p'] \geq \frac{-\mathbf{m}_0[p']}{n - \mathbf{m}_0[p]}$. Applying this inequality to $\alpha(n)$ and letting n go to infinity yields $\mathbf{w}[p'] \geq 0$.

Due to standard results of polyhedra theory (see [1] for instance), the set $\{C_{P \times T'} \mathbf{u} \mid \mathbf{u} \in \mathbb{R}_{\geq 0}^{T'}\}$ is closed. So there exists $\mathbf{u} \in \mathbb{R}_{\geq 0}^{T'}$ such that $\mathbf{w} = C\mathbf{u}$. Considering \mathbf{u} as a vector of $\mathbb{R}_{\geq 0}^T$ by adding null components for $T \setminus T'$ yields the required vector. ■

Example. Let us illustrate the boundedness characterisation on the CPN system depicted below. The solutions of the equation system $C\mathbf{v} \succeq \mathbf{0}$ are $x\vec{t}_2$ with $x > 0$. On the other hand, $\max\text{FS}(\mathcal{N}, \mathbf{m}_0) = \{t_1, t_2\}$. So the CPN system is unbounded. Observe that considering it as a (discrete) Petri net, this net is bounded.

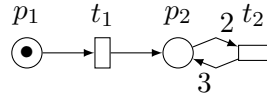

4. Decision procedures

Naively implementing the characterisation of reachability would lead to an exponential procedure since it would require to enumerate the items of $FS(\mathcal{N}, \mathbf{m}_0)$ (whose size is possibly exponential). For each item, say T' , the algorithm would check in polynomial time (1) whether T' belongs to $FS(\mathcal{N}^{-1}, \mathbf{m})$ and (2) whether the associated linear program $\mathbf{v} > \mathbf{0} \wedge C_{P \times T'} \mathbf{v} = \mathbf{m} - \mathbf{m}_0$ admits a solution. Guessing T' shows that the reachability problem belongs to NP.

In fact, we improve this upper bound with the help of Algorithm 2. When $\mathbf{m} \neq \mathbf{m}_0$, this algorithm maintains a subset of transitions T' which fulfills $\llbracket \vec{\sigma} \rrbracket \subseteq T'$ for any $\mathbf{m}_0 \xrightarrow{\sigma} \mathbf{m}$ (as will be proven in proposition 26). Initially T' is set to T . Then lines 4-9 build a solution to the state equation restricted to transitions of T' with a maximal support (if there is at least one). If there is no solution then the algorithm returns false. Otherwise T' is successively restricted to (1) the support of this maximal solution (line 10), (2) the maximal firing set in $\max\text{FS}(\mathcal{N}_{T'}, \mathbf{m}_0[\bullet T' \bullet])$ (line 11) and, (3) the maximal firing set in $\max\text{FS}(\mathcal{N}_{T'}^{-1}, \mathbf{m}[\bullet T' \bullet])$ (line 12). If the two last restrictions do not modify T' then the algorithm returns true. If T' becomes empty then the algorithm returns false.

Omitting line 12, Algorithm 2 decides the lim-reachability problem.

Proposition 26. Algorithm 2 returns true iff \mathbf{m} is reachable in $\langle \mathcal{N}, \mathbf{m}_0 \rangle$. Algorithm 2 without line 12 returns true iff \mathbf{m} is lim-reachable in $\langle \mathcal{N}, \mathbf{m}_0 \rangle$.

Proof. We only consider the non trivial case $\mathbf{m} \neq \mathbf{m}_0$.

Soundness. Assume that the algorithm returns true at line 13.

By definition, vector sol which is a barycenter of solutions is also a solution with maximal support and

Algorithm 2: Decision algorithm for reachability

 Reachable($\langle \mathcal{N}, \mathbf{m}_0 \rangle, \mathbf{m}$): status

Input: a CPN system $\langle \mathcal{N}, \mathbf{m}_0 \rangle$, a marking \mathbf{m}
Output: the reachability status of \mathbf{m}
Output: the Parikh image of a witness in the positive case

Data: *nbsol*: integer; *v*, *sol*: vectors; T' : subset of transitions

```

1 if  $\mathbf{m} = \mathbf{m}_0$  then return (true,0)
2  $T' \leftarrow T$ 
3 while  $T' \neq \emptyset$  do
4    $nbsol \leftarrow 0$ ;  $\mathbf{sol} \leftarrow \mathbf{0}$ 
5   for  $t \in T'$  do
6     solve  $\exists \mathbf{v} \mathbf{v} \geq \mathbf{0} \wedge \mathbf{v}[t] > 0 \wedge \mathbf{C}_{P \times T'} \mathbf{v} = \mathbf{m} - \mathbf{m}_0$ 
7     if  $\exists \mathbf{v}$  then  $nbsol \leftarrow nbsol + 1$ ;  $\mathbf{sol} \leftarrow \mathbf{sol} + \mathbf{v}$ 
8   end
9   if  $nbsol = 0$  then return false else  $\mathbf{sol} \leftarrow \frac{1}{nbsol} \mathbf{sol}$ 
10   $T' \leftarrow \llbracket \mathbf{sol} \rrbracket$ 
11   $T' \leftarrow T' \cap \max\text{FS}(\mathcal{N}_{T'}, \mathbf{m}_0[\bullet T' \bullet])$ 
12   $T' \leftarrow T' \cap \max\text{FS}(\mathcal{N}_{T'}^{-1}, \mathbf{m}[\bullet T' \bullet])$  /* deleted for lim-reachability */
13  if  $T' = \llbracket \mathbf{sol} \rrbracket$  then return (true,  $\mathbf{sol}$ )
14 end
15 return false

```

so fulfils the first statement of Theorem 20. Since $T' = \llbracket \text{sol} \rrbracket$ at line 13, $\llbracket \text{sol} \rrbracket \in FS(\mathcal{N}, \mathbf{m}_0)$ due to line 11 and $\llbracket \text{sol} \rrbracket \in FS(\mathcal{N}^{-1}, \mathbf{m})$ due to line 12. Thus \mathbf{m} is reachable in $\langle \mathcal{N}, \mathbf{m}_0 \rangle$ since it fulfils the assertions of Theorem 20. In case of lim-reachability, line 12 is omitted. So the assertions of Theorem 21 are fulfilled and \mathbf{m} is lim-reachable in $\langle \mathcal{N}, \mathbf{m}_0 \rangle$.

Completeness. Assume the algorithm returns false.

We claim that at any time the algorithm fulfils the following invariant: for any $\mathbf{m}_0 \xrightarrow{\sigma} \mathbf{m}$, $\llbracket \vec{\sigma} \rrbracket \subseteq T'$. This invariant initially holds since $T' = T$. At line 10 due to the first assertion of Theorem 20, for any such σ , $\llbracket \vec{\sigma} \rrbracket \subseteq \llbracket \text{sol} \rrbracket$ since sol is a solution with maximal support. So the assignment of line 10 lets true the invariant. Due to the second assertion of Theorem 20 and the invariant, any σ fulfils $\llbracket \vec{\sigma} \rrbracket \subseteq \maxFS(\mathcal{N}_{T'}, \mathbf{m}_0[\bullet T' \bullet])$. So the assignment of line 11 lets true the invariant. Due to the third assertion of Theorem 20 and the invariant, any σ fulfils $\llbracket \vec{\sigma} \rrbracket \subseteq \maxFS(\mathcal{N}_{T'}^{-1}, \mathbf{m}[\bullet T' \bullet])$. So the assignment of line 12 lets true the invariant.

If the algorithm returns false at line 9 due to the invariant the first assertion of Theorem 20 cannot be satisfied. If the algorithm returns false at line 15 then $T' = \emptyset$. So due to the invariant and since $\mathbf{m} \neq \mathbf{m}_0$, \mathbf{m} is not reachable from \mathbf{m}_0 .

The case of lim-reachability is similarly handled with the following invariant: for any $\mathbf{m}_0 \xrightarrow{\sigma} \infty \mathbf{m}$, $\llbracket \vec{\sigma} \rrbracket \subseteq T'$. ■

Proposition 27. The reachability and the lim-reachability problems for CPN systems are decidable in polynomial time.

Proof. Let us analyse the time complexity of Algorithm 2. Since T' must be modified in lines 11 or 12 in order to start a new iteration of the main loop, there are at most $|T|$ iterations of this loop. The number of iterations of the inner loop is also bounded by $|T|$. Finally solving a linear program can be performed in polynomial time [13] as well as computing the maximal item of a firing set (see Corollary 19). ■

In [10], it is proven that the lim-reachability problem for consistent CPN systems with no empty siphons in the initial marking is decidable in polynomial time. We improve this result by showing that this problem and a similar one belong to $\text{NC} \subseteq \text{PTIME}$ (a complexity class of problems that can take advantage of parallel computations, see [12]).

Proposition 28. The reachability problem for consistent CPN systems with no empty siphons in the initial marking and no empty siphons in the final marking for the reverse net belongs to NC .

The lim-reachability problem for consistent CPN systems with no empty siphons in the initial marking belongs to NC .

Proof. Due to the assumptions on siphons and proposition 18 only the first assertion of Theorems 20 and 21 needs to be checked. Due to consistency, there exists $\mathbf{w} > \mathbf{0}$ such that $C\mathbf{w} = \mathbf{0}$. Assume there is some $\mathbf{v} \in \mathbb{R}^T$ such that $\mathbf{m} - \mathbf{m}_0 = C\mathbf{v}$. For some $n \in \mathbb{N}$ large enough, $\mathbf{v}' \stackrel{\text{def}}{=} \mathbf{v} + n\mathbf{w} \in \mathbb{R}_{\geq 0}^T$ and still fulfils $\mathbf{m} - \mathbf{m}_0 = C\mathbf{v}'$.

Now the decision problem $\exists \mathbf{v} \in \mathbb{R}^T \mathbf{m} - \mathbf{m}_0 = C\mathbf{v}$ belongs to NC [4]. ■

Based on Theorems 23 and 24, we follow the same lines for designing Algorithm 3 which decides (lim-)coverability.

Proposition 29. The coverability and the lim-coverability problems for CPN systems are decidable in polynomial time.

Algorithm 3: Decision algorithm for coverability

```

Coverable( $\langle \mathcal{N}, \mathbf{m}_0 \rangle, \mathbf{m}$ ): status
Input: a CPN system  $\langle \mathcal{N}, \mathbf{m}_0 \rangle$ , a marking  $\mathbf{m}$ 
Output: the coverability status of  $\mathbf{m}$ 
Output: the Parikh image of a witness in the positive case
Data:  $nbsol$ : integer;  $\mathbf{v}, \mathbf{solv}$ : vectors over transitions;  $T'$ : subset of transitions
Data:  $\mathbf{w}, \mathbf{solw}$ : vectors over places
1 if  $\mathbf{m} \leq \mathbf{m}_0$  then return (true,0)
2  $T' \leftarrow T$ 
3 while  $T' \neq \emptyset$  do
4    $nbsol \leftarrow 0$ ;  $\mathbf{solv} \leftarrow \mathbf{0}$ ;  $\mathbf{solw} \leftarrow \mathbf{0}$ 
5   for  $t \in T'$  do
6     solve  $\exists? \mathbf{v}, \mathbf{w} \mathbf{v} \geq \mathbf{0} \wedge \mathbf{w} \geq \mathbf{0} \wedge \mathbf{v}[t] > 0 \wedge \mathbf{C}_{P \times T'} \mathbf{v} - \mathbf{w} = \mathbf{m} - \mathbf{m}_0$ 
7     if  $\exists \mathbf{v}, \mathbf{w}$  then  $nbsol \leftarrow nbsol + 1$ ;  $\mathbf{solv} \leftarrow \mathbf{solv} + \mathbf{v}$ ;  $\mathbf{solw} \leftarrow \mathbf{solw} + \mathbf{w}$ 
8   end
9   /* The next loop is deleted for lim-coverability */
10  for  $p \in P$  do
11    solve  $\exists? \mathbf{v}, \mathbf{w} \mathbf{v} \geq \mathbf{0} \wedge \mathbf{w} \geq \mathbf{0} \wedge \mathbf{w}[p] > 0 \wedge \mathbf{C}_{P \times T'} \mathbf{v} - \mathbf{w} = \mathbf{m} - \mathbf{m}_0$ 
12    if  $\exists \mathbf{v}$  then  $nbsol \leftarrow nbsol + 1$ ;  $\mathbf{solv} \leftarrow \mathbf{solv} + \mathbf{v}$ ;  $\mathbf{solw} \leftarrow \mathbf{solw} + \mathbf{w}$ 
13  end
14  if  $nbsol = 0$  then return false else  $\mathbf{solv} \leftarrow \frac{1}{nbsol} \mathbf{solv}$ ;  $\mathbf{solw} \leftarrow \frac{1}{nbsol} \mathbf{solw}$ 
15   $T' \leftarrow \llbracket \mathbf{solv} \rrbracket$ 
16   $T' \leftarrow T' \cap \max\text{FS}(\mathcal{N}_{T'}, \mathbf{m}_0[\bullet T' \bullet])$ 
17  /* The next line deleted for lim-coverability */
18   $T' \leftarrow T' \cap \max\text{FS}(\mathcal{N}_{T'}^{-1}, (\mathbf{m} + \mathbf{solw})[\bullet T' \bullet])$ 
19  if  $T' = \llbracket \mathbf{solv} \rrbracket$  then return (true,  $\mathbf{solv}$ )
20 end
21 return false

```

Proof. The polynomial time complexity of Algorithm 3 is established similarly as the one of Algorithm 2. Let us focus on the correctness of the algorithm. We only handle the case of coverability since the case of lim-coverability is similar and even simpler.

Soundness. Assume that the algorithm returns true at line 17.

By definition, the pair $(\mathbf{solv}, \mathbf{solw})$ which is a barycenter of solutions is also a solution with maximal support and so fulfils the first statement of Theorem 23. Since $T' = \llbracket \mathbf{solv} \rrbracket$ at line 17, $\llbracket \mathbf{solv} \rrbracket \in FS(\mathcal{N}, \mathbf{m}_0)$ due to line 15 and $\llbracket \mathbf{solv} \rrbracket \in FS(\mathcal{N}^{-1}, \mathbf{m} + \mathbf{solw})$ due to line 16. Thus \mathbf{m} is coverable in $\langle \mathcal{N}, \mathbf{m}_0 \rangle$ since it fulfils the assertions of Theorem 23.

Completeness. Assume the algorithm returns false.

We claim that at any time the algorithm fulfils the following invariant: for any σ such that there exists $\mathbf{m}' \geq \mathbf{m}$ with $\mathbf{m}_0 \xrightarrow{\sigma} \mathbf{m}'$, $\llbracket \vec{\sigma} \rrbracket \subseteq T'$.

This invariant initially holds since $T' = T$. At line 14 due to the first assertion of Theorem 23, for any such σ , $\llbracket \vec{\sigma} \rrbracket \subseteq \llbracket \mathbf{solv} \rrbracket$ and $\llbracket \mathbf{m}' \rrbracket \subseteq \llbracket \mathbf{m} + \mathbf{solw} \rrbracket$ since the pair $(\mathbf{solv}, \mathbf{solw})$ is a solution with maximal support. So the assignment of line 14 lets true the invariant. Due to the second assertion of Theorem 23 and the invariant, any σ fulfils $\llbracket \vec{\sigma} \rrbracket \subseteq \maxFS(\mathcal{N}_{T'}, \mathbf{m}_0[\bullet T' \bullet])$. So the assignment of line 15 lets true the invariant. Due to the third assertion of Theorem 23 and the invariant, any pair (σ, \mathbf{m}') fulfils $\llbracket \vec{\sigma} \rrbracket \subseteq \maxFS(\mathcal{N}_{T'}^{-1}, \mathbf{m}'[\bullet T' \bullet]) \subseteq \maxFS(\mathcal{N}_{T'}^{-1}, (\mathbf{m} + \mathbf{solw})[\bullet T' \bullet])$. So the assignment of line 16 lets true the invariant.

If the algorithm returns false at line 13 then, due to the invariant, the first assertion of Theorem 23 cannot be satisfied. If the algorithm returns false at line 19 then $T' = \emptyset$. So due to the invariant and since $\mathbf{m} \not\leq \mathbf{m}_0$, \mathbf{m} is not coverable from \mathbf{m}_0 . ■

Proposition 30. The boundedness problem for CPN systems is decidable in polynomial time.

Proof. Using the characterisation of Theorem 25, one computes in polynomial time $T' = \maxFS(\mathcal{N}, \mathbf{m}_0)$ (see Corollary 19). Then for all $p \in P$, one solves the existential linear program:

$$\exists? \mathbf{v} \geq \mathbf{0} \mathbf{C}_{P \times T'} \mathbf{v} \geq \mathbf{0} \wedge (\mathbf{C}_{P \times T'} \mathbf{v})[p] > 0$$

The CPN system is unbounded if some of these linear programs admits a solution. ■

In discrete Petri nets, the reachability set inclusion problem is undecidable, while the restricted problem of home state is decidable (see [8] for a detailed survey about decidability results in PNs). In CPN systems, this problem is decidable thanks to the special structure of the (lim-)reachability sets.

Proposition 31. The reachability set inclusion and the lim-reachability set inclusion problems for CPN systems are decidable in exponential time.

Proof. Let us define $TP \stackrel{\text{def}}{=} \{(T', P') \mid T' \in FS(\mathcal{N}, \mathbf{m}_0) \wedge T' \neq \emptyset \wedge P' \subseteq P \wedge T' \in FS(\mathcal{N}^{-1}, P')\}$. For every pair $(T', P') \in TP$, define the polyhedron $E_{T', P'}$ over $\mathbb{R}^P \times \mathbb{R}^{T'}$ by:

$$E_{T', P'} \stackrel{\text{def}}{=} \{(\mathbf{m}, \mathbf{v}) \mid \mathbf{m}[P'] > \mathbf{0} \wedge \mathbf{m}[P \setminus P'] = \mathbf{0} \wedge \mathbf{v} > \mathbf{0} \wedge \mathbf{m} = \mathbf{m}_0 + \mathbf{C}_{P \times T'} \mathbf{v}\}$$

and $R_{T', P'}$ by: $R_{T', P'} \stackrel{\text{def}}{=} \{\mathbf{m} \mid \exists \mathbf{v} (\mathbf{m}, \mathbf{v}) \in E_{T', P'}\}$

Using the characterisation of Theorem 20 and Lemma 16,

$$RS(\mathcal{N}, \mathbf{m}_0) = \{\mathbf{m}_0\} \cup \bigcup_{(T', P') \in TP} R_{T', P'}.$$

Due to Lemma 12, the reachability set of a CPN system is convex. So $RS(\mathcal{N}, \mathbf{m}_0)$ can be rewritten as:

$$RS(\mathcal{N}, \mathbf{m}_0) = \left\{ \lambda_0 \mathbf{m}_0 + \sum_{(T', P') \in TP} \lambda_{T', P'} \mathbf{m}_{T', P'} \mid \right. \\ \left. \lambda_0 + \sum_{(T', P') \in TP} \lambda_{T', P'} = 1 \wedge \lambda_0 \geq 0 \wedge \forall (T', P') \in TP \lambda_{T', P'} \geq 0 \wedge \mathbf{m}_{T', P'} \in R_{T', P'} \right\}$$

Observe that this representation is exponential w.r.t. the size of the CPN system.

Let $\langle \mathcal{N}, \mathbf{m}_0 \rangle$ and $\langle \mathcal{N}', \mathbf{m}'_0 \rangle$ be two CPN systems for which one wants to check whether $RS(\mathcal{N}, \mathbf{m}_0) \subseteq RS(\mathcal{N}', \mathbf{m}'_0)$. One builds the representation above for $RS(\mathcal{N}, \mathbf{m}_0)$ and $RS(\mathcal{N}', \mathbf{m}'_0)$. Then one transforms the representation of the set $RS(\mathcal{N}', \mathbf{m}'_0)$ as a system of linear constraints. This can be done in polynomial time w.r.t. the original representation [2]. So the number of constraints is still exponential w.r.t. the size of $\langle \mathcal{N}', \mathbf{m}'_0 \rangle$.

Afterwards for every constraint of this new representation, one adds its negation to the representation of $RS(\mathcal{N}, \mathbf{m}_0)$ and check for a solution of such a system. $RS(\mathcal{N}, \mathbf{m}_0) \not\subseteq RS(\mathcal{N}', \mathbf{m}'_0)$ iff at least one of these linear programs admits a solution. The overall complexity of this procedure is still exponential w.r.t. the size of the problem.

The procedure for lim-reachability set inclusion is similar. We first observe that:

$$\text{lim-RS}(\mathcal{N}, \mathbf{m}_0) = \{\mathbf{m}_0\} \cup \bigcup_{\emptyset \neq T' \in FS(\mathcal{N}, \mathbf{m}_0)} \{ \mathbf{m} \mid \exists \mathbf{v} > \mathbf{0} \mathbf{m} = \mathbf{m}_0 + \mathbf{C}_{P \times T'} \mathbf{v} \}$$

Due to Lemma 12, the lim-reachability set of a CPN system is convex. So we proceed as before. ■

5. Hardness results

We now provide matching lower bounds for almost all problems analysed in the previous sections. There are two lower bounds: PTIME and coNP. The difference of complexity between the problems can be illustrated by contrasting the reachability problem and the deadlock-freeness problem. While the search of a firing sequence for the reachability can be done in polynomial time, to falsify the deadlock-freeness one looks for a dead marking and then checks that this marking is reachable. Unfortunately the guess of dead marking cannot be avoided by a deterministic procedure operating in polynomial time (as shown by the lower bound below).

Proposition 32. The reachability, lim-reachability, coverability, lim-coverability and boundedness problems for CPN systems are PTIME-complete.

Proof. Due to propositions 27 and 30, we only have to prove that these problems are PTIME-hard. So we design a LOGSPACE reduction from the circuit value problem (a PTIME-complete problem [12]) to these problems.

A circuit \mathcal{C} is composed of four kinds of gates: False, True, AND, OR. Each gate has an output. There is a single False gate and a single True gate and they have no inputs. Gates whose type is AND or OR

have two inputs. Any input of a gate is connected to an output of another gate. Let the binary relation \prec between the gates be defined by: $a \prec b$ if the output of a is connected to an input of b . Then one requires that the transitive closure of \prec is irreflexive. One of the gates of the circuit, out , is distinguished and its output is not the input of any gate. The value of the inputs and outputs of a circuit is defined inductively according to the relation \prec . The output of gate **False** (resp. **True**) is **false** (resp. **true**). The input of a gate is equal to the value of the output to which it is connected. The output of a gate **AND** or **OR** is obtained by applying its truth table to its inputs. The circuit value problem consists in determining the value of the output of gate out .

The reduction is done as follows: The gate **True** is modelled by a place p_{True} initially containing a token. This is the only place initially marked. The gate **False** is modelled by a place p_{False} . Any gate c of kind **AND** yields a place p_c and a transition t_c whose inputs and outputs is represented in Fig. 4(a) and any gate c of kind **OR** yields a place p_c and two transitions t_{c1} and t_{c2} whose inputs and outputs are represented in Fig. 4(b). Finally one adds the subnet represented in Fig. 5 with one transition $clean_p$ per place p different from p_{out} . This reduction can be performed in LOGSPACE.

We prove by induction on \prec that a transition t_c (resp. t_{c1} or t_{c2}) is enabled iff the gate c of kind **AND** (resp. **OR**) has value **true**.

Assume that gate c of kind **AND** has value **false**. Then one of its input say a has value **false**. If a is the gate **False** then p_a is initially unmarked and cannot be marked since it has no input. If a is a gate of kind **AND** then by induction on \prec , t_a is never enabled and so p_a will always be empty. If a is a gate of kind **OR** then by induction on \prec , t_{a1} and t_{a2} are never enabled and so p_a will always be empty. Thus whatever the case t_c can never be enabled. The case of a gate c of kind **OR** is similar.

Assume that gate c of kind **AND** has value **true**. Then both its inputs say a and b have value **true**. If a (resp. b) is the gate **True** then p_a (resp. p_b) is initially marked. If a (resp. b) is a gate of kind **AND** then by induction on \prec , t_a (resp. t_b) can be enabled. If a is a gate of kind **OR** then by induction on \prec , some t_{ai} (resp. t_{bi}) can be enabled. Now consider the sequence $m_0 \xrightarrow{\sigma} m$ of Proposition 18 w.r.t. $\max\text{FS}(\mathcal{N}, m_0)$. In m , every place initially marked or output of a transition that belongs to $\max\text{FS}(\mathcal{N}, m_0)$ is marked. So t_c is enabled in m . The case of a gate c of kind **OR** is similar.

Now observe that the total amount of tokens in the net can only be increased by transition $grow$ and in this case place p_{out} is unbounded. Since p_{out} can contain tokens iff the value of gate out is **true**, we have proved that the CPN system is unbounded iff the gate out is **true**.

Finally let m be defined by $m(p_{out}) = 1$ and $m(p) = 0$ for all $p \neq p_{out}$. If the value of gate out is **false** then p_{out} will never be marked and consequently m is neither (lim-)reachable nor (lim-)coverable. If the value of gate out is **true** then transition t_{out} can be fired by some small amount say $0 < \varepsilon \leq 1$. Then all the other places can be unmarked by transitions $clean_p$ followed by a finite number of firings of $grow$ in order to reach m . So m is (lim-)reachable (and (lim-)coverable) iff the value of gate out is **true**. ■

The next propositions establish coNP-hardness for some problems of CPNs. Furthermore we want to show that these lower bounds are robust i.e. that they hold for subclasses of CPNs. To this aim, we recall free-choice CPNs.

Definition 33. A CPN \mathcal{N} is free-choice if:

- $\forall p \in P \forall t \in T \{ \mathbf{Pre}[p, t], \mathbf{Post}[p, t] \} \subseteq \{0, 1\}$;

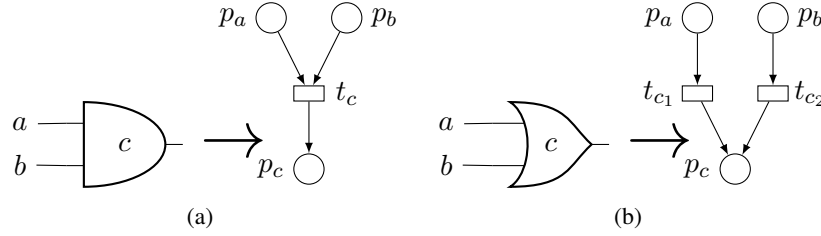

Figure 4. Reductions of the gates (a) AND and (b) OR to CPN.

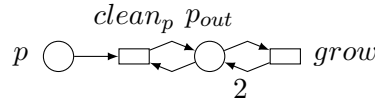

Figure 5. An additional subnet.

$$\bullet \forall t, t' \in T \bullet t \cap \bullet t' \neq \emptyset \Rightarrow \bullet t = \bullet t'.$$

It is shown in [14] that the (lim-)deadlock-freeness and (lim-)liveness problems in free-choice CPN systems belong to coNP. We prove below that they are in fact coNP-complete.

Proposition 34. The (lim-)deadlock-freeness and (lim-)liveness problems in free-choice CPN systems are coNP-hard.

Proof. We use almost the same reduction from the 3SAT problem as the one proposed for free-choice Petri nets in [6]. However the proof of correctness is specific to continuous nets.

Let $\{x_1, x_2, \dots, x_n\}$ denote the set of propositions and $\{c_1, c_2, \dots, c_m\}$ denote the set of clauses. Every clause c_j is defined by $c_j \stackrel{\text{def}}{=} lit_{j1} \vee lit_{j2} \vee lit_{j3}$ where for all j, k , $lit_{jk} \in \{x_1, \dots, x_n, \neg x_1, \dots, \neg x_n\}$. The satisfiability problem consists in the existence of an interpretation

$$\nu : \{x_1, x_2, \dots, x_n\} \longrightarrow \{\text{false}, \text{true}\}$$

such that for all clause c_j , $\nu(c_j) = \text{true}$.

Every proposition x_i yields a place b_i initially marked with a token (all other places are unmarked) and input of two transitions t_i, f_i corresponding to the assignment associated with an interpretation. Every of literal lit_{jk} yields a place l_{jk} which is the output of transition t_i if $lit_{jk} = x_i$ or transition f_i if $lit_{jk} = \neg x_i$. Every clause c_j yields a transition nc_j with three input “literal” places corresponding to literals $\neg lit_{j1}, \neg lit_{j2}, \neg lit_{j3}$. An additional place suc is the output of every transition nc_j . Finally, transition $back$ has suc as a loop place and b_i for all i as output places. The reduction is illustrated in Fig. 6.

Assume that there exists ν such that for all clause c_j , $\nu(c_j) = \text{true}$. Then fire the following sequence $\sigma = 1t_1^* \dots 1t_n^*$ where $t_i^* = t_i$ when $\nu(x_i) = \text{true}$ and $t_i^* = f_i$ when $\nu(x_i) = \text{false}$. Consider m the reached marking. Since $\nu(c_j) = \text{true}$, at least one input place of nc_j is empty in m . Moreover $m(suc) = m(b_i) = 0$ for all i . So m is dead.

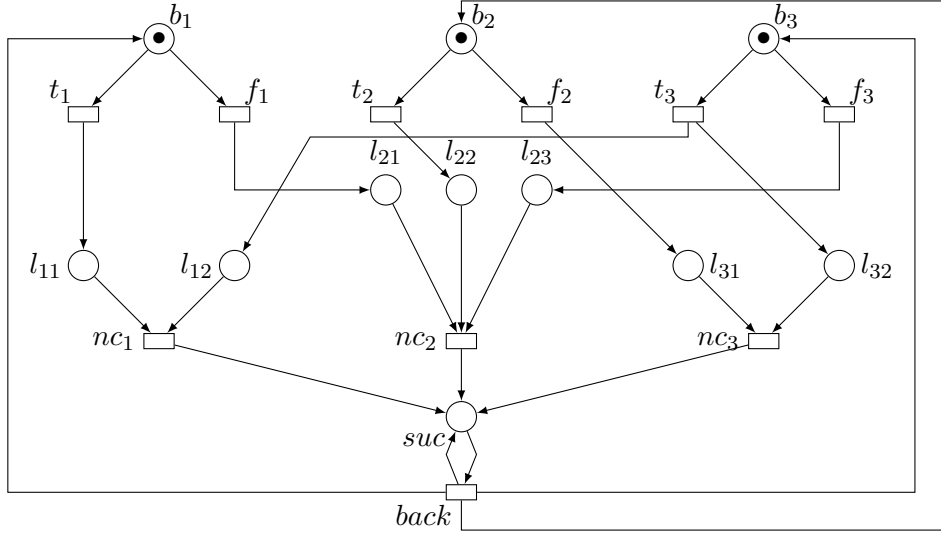

Figure 6. The CPN corresponding to formula $(\neg x_1 \vee \neg x_3) \wedge (x_1 \vee \neg x_2 \vee x_3) \wedge (x_2 \vee \neg x_3)$.

Assume that there does not exist ν such that for all clause c_j , $\nu(c_j) = \mathbf{true}$. Observe that given a marking \mathbf{m} such that $\mathbf{m}(suc) > 0$ all transitions will be fireable in the future and suc will never decrease (thus $\mathbf{m}(suc) > 0$ for a lim-reachable marking \mathbf{m} as well).

So we only consider reachable marking \mathbf{m} such that $\mathbf{m}(suc) = 0$, i.e. when no transitions nc_j have been fired. Our goal is to prove that from such marking there is a sequence that produces tokens in suc . Examining the remaining transitions, the following invariants hold. For all atomic proposition x_i , and reachable marking \mathbf{m} , one has

$$\forall i \mathbf{m}[b_i] + \sum_{lit_{jk} \in \{x_i, \neg x_i\}} \mathbf{m}[l_{jk}] \geq 1$$

$$\forall j, k, j', k' lit_{jk} = lit_{j'k'} \Rightarrow \mathbf{m}[l_{jk}] = \mathbf{m}[l_{j'k'}]$$

If for some i , $\mathbf{m}[b_i] > 0$, we fire t_i in order to empty b_i . Thus the invariants become:

$$\forall i \sum_{lit_{jk} \in \{x_i, \neg x_i\}} \mathbf{m}[l_{jk}] \geq 1$$

$$\forall j, k, j', k' lit_{jk} = lit_{j'k'} \Rightarrow \mathbf{m}[l_{jk}] = \mathbf{m}[l_{j'k'}]$$

Now define ν by $\nu(x_i) = \mathbf{true}$ if for some $lit_{jk} = x_i$, $\mathbf{m}[l_{jk}] > 0$. Due to the hypothesis, there is a clause c_j such that $\nu(c_j) = \mathbf{false}$. Due to our choice of ν and the invariants, all inputs of nc_j are marked. So firing nc_j marks suc . ■

We show that even the hypotheses that allow the lim-reachability to belong in NC (see Proposition 28) do not reduce the complexity of other problems.

Proposition 35. The (lim-)deadlock-freeness, (lim-)liveness and reversibility problems in consistent CPN systems with no initially empty siphons are coNP-hard.

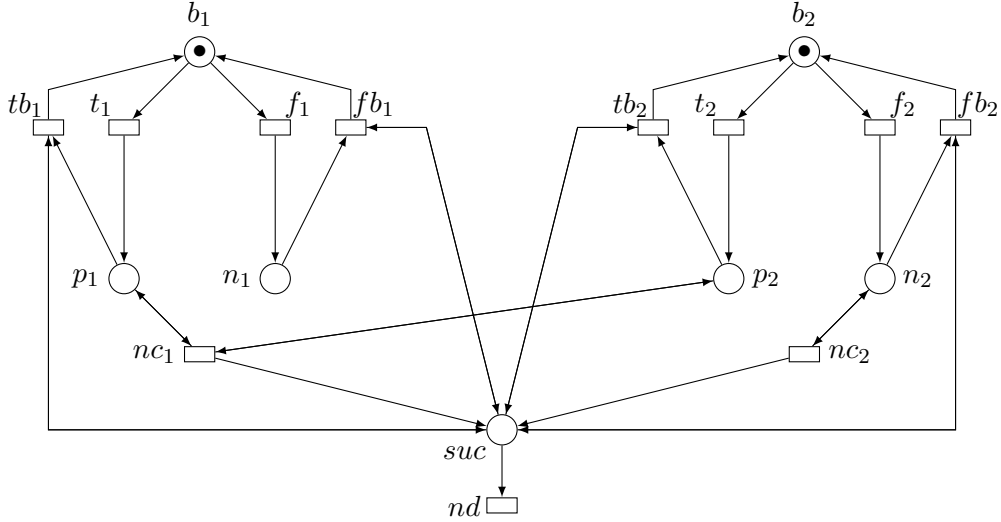

Figure 7. The CPN corresponding to formula $(\neg x_1 \vee \neg x_2) \wedge x_2$.

Proof. We use another reduction from the 3SAT problem already described in the proof of proposition 34. Every proposition x_i yields a place b_i initially marked with a token (all other places are unmarked) and input of two transitions: (1) t_i with output place p_i and, (2) f_i with output place n_i corresponding to the assignment associated with an interpretation. Every clause c_j yields a transition nc_j . Transition nc_j has three loop places corresponding to literals lit_{jk} : if $lit_{jk} = x_i$ then the input is n_i , if $lit_{jk} = \neg x_i$ then the input is p_i . An additional place suc is the output of transition nc_j . A transition nd has suc for input place and no output place. Finally for every x_i , there are transitions tb_i and fb_i which are respectively reverse transitions of t_i and f_i with an additional loop over place suc . The reduction is illustrated in Fig. 7. The net is consistent with consistency vector: $\sum_i (t_i + tb_i + f_i + fb_i) + \sum_j (nc_j + nd)$. It does not contain an initially empty siphon since every siphon includes some place b_i . This proves that every transition can be fired at least once from \mathbf{m}_0 .

Assume that there exists ν such that for all clause c_j , $\nu(c_j) = \mathbf{true}$. Then fire the following sequence $\sigma = 1t_1^* \dots 1t_n^*$ where $t_i^* = t_i$ when $\nu(x_i) = \mathbf{true}$ and $t_i^* = f_i$ when $\nu(x_i) = \mathbf{false}$. Consider \mathbf{m} the reached marking. Since $\nu(c_j) = \mathbf{true}$, at least one input place of nc_j is empty in \mathbf{m} . Moreover $\mathbf{m}(suc) = \mathbf{m}(b_i) = 0$ for all i . So \mathbf{m} is dead and the net is not reversible.

Assume that there does not exist ν such that for all clause c_j , $\nu(c_j) = \mathbf{true}$. Our goal is to prove that from any (lim-)reachable marking there is a sequence that comes back to \mathbf{m}_0 . Since from \mathbf{m}_0 all transitions are fireable at least once this proves that the net is (lim-)live and (lim-)deadlock free.

For all atomic proposition x_i , and reachable marking \mathbf{m} , one has

$$\forall i \mathbf{m}[b_i] + \mathbf{m}[p_i] + \mathbf{m}[n_i] = 1$$

Since a lim-reachable marking is a limit of reachable markings, this invariant also holds for lim-reachable markings.

If for some i , $\mathbf{m}[b_i] > 0$, we fire t_i in order to empty b_i . So the invariant becomes: $\forall i \mathbf{m}[p_i] + \mathbf{m}[n_i] = 1$. Now define ν by $\nu(x_i) = \mathbf{true}$ if $\mathbf{m}(p_i) > 0$. Due to the hypothesis, there is a clause c_j such that

$\nu(c_j) = \text{false}$. Due to our choice of ν and the invariant, all inputs of nc_j are marked. So firing nc_j marks suc . Now fire transitions tb_i and fb_i in order to empty places p_i and n_i . So $m(b_i) = 1$. Finally one fires nd in order to empty place suc and we are done. ■

6. Application to a case study: a manufacturing system

6.1. Modelling a flexible manufacturing system

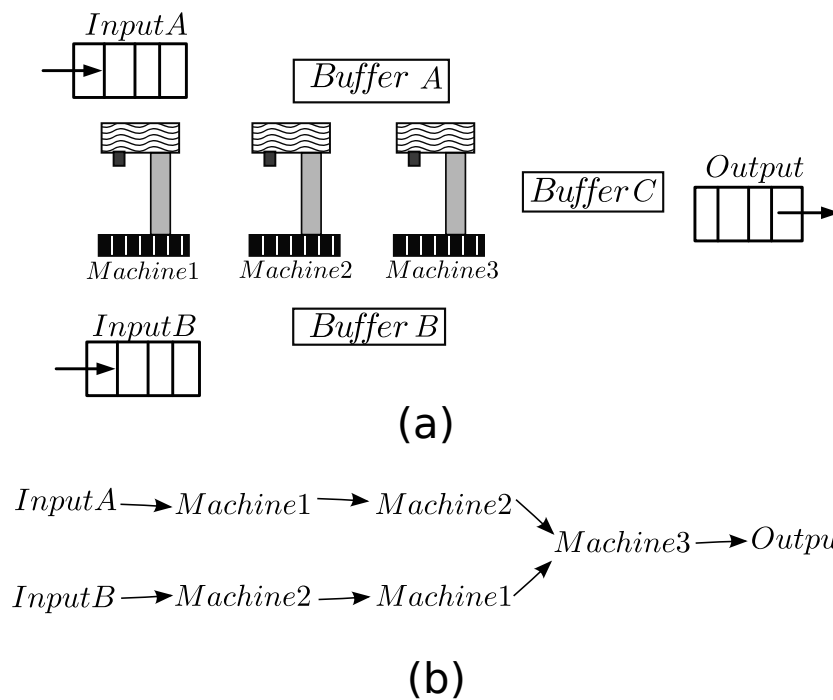

Figure 8. (a) Logical layout of a manufacturing system; and (b) its production process

Let us consider a *flexible manufacturing system* which consists of three machines [11], in which some *competition* and *cooperation* relations appear (see Fig. 9(a)). The production process consists of two production lines (see Fig. 9) in which subproducts A and B are produced. Subproduct A is first processed by *Machine1* and then processed by *Machine2*, while subproduct B is processed in the opposite order. Once both subproducts are processed, they are *assembled* by *Machine3*, to obtain the final product.

The flexible manufacturing system in Fig. 8 is modeled by the PN in Fig. 9. Places p_{17} and p_{18} represent the availability of *Machine1* and *Machine2*, respectively. Places $\{p_i\}_{1 \leq i \leq 5}$ represent the processing of subproduct A, which is first processed by *Machine1* (place p_{17}), and then by *Machine2* (place p_{18}). The number of subproducts A which can be simultaneously be processed is determined by the initial marking in p_2 . Subproduct A is stored in *Buffer A* (place p_6), whose size is determined by the initial marking of place p_1 . Places $\{p_i\}_{7 \leq i \leq 12}$ model the processing and storage of Subproduct B. *Machine3* (p_{13} models the idle machine) assembles the subproducts obtained from p_6 and p_{12} and it

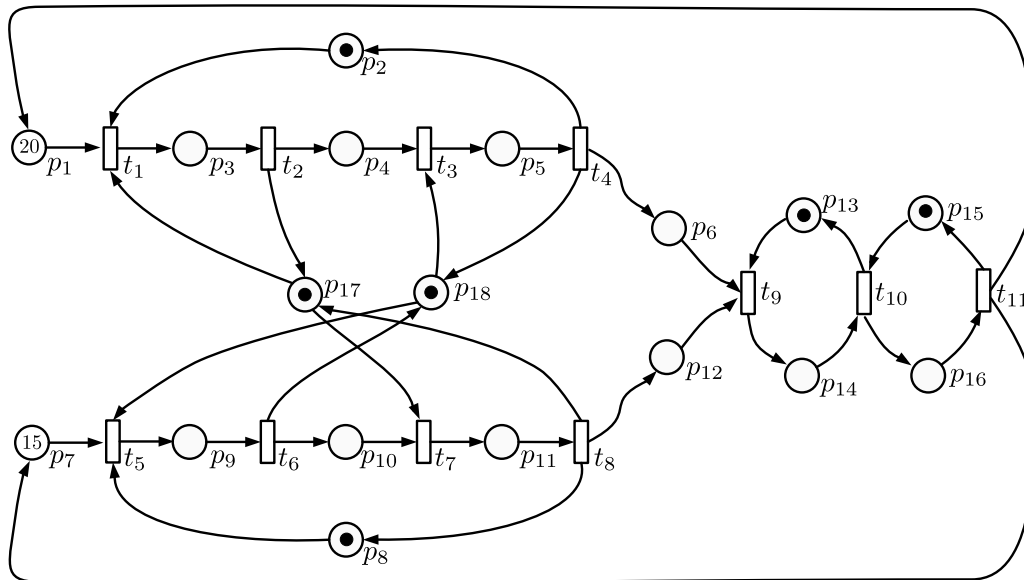

Figure 9. A PN which models the FMS of Figure 8 (see [11])

stores them in the *Buffer C*. Place p_{15} represents the size of *Buffer C*. In the initial marking depicted in the figure, the sizes of *Buffer A*, *Buffer B* and *Buffer C*, are 20, 15 and 1 respectively, and these buffers are initially empty. So only a Subproduct A and a Subproduct B can be initially produced.

6.2. Properties analysis

If the net of Figure 9 is considered as a discrete PN, its reachability space has 15,455 markings and its size grows exponentially with the sizes of the buffer.

Reachability. It is interesting to check whether *Buffer A* and *Buffer B* can be simultaneously full with *Machine1* and *Machine2* idle. This would be a good situation for the manufacturing plant to perform some cleanace tasks over both machines. Several markings witness such a situation like $\mathbf{m}_1 = p_2 + 20p_6 + 15p_{12} + p_{13} + p_{15} + p_{17} + p_{18}$. Algorithm 2 establishes that \mathbf{m}_1 is reachable in $\langle \mathcal{N}, \mathbf{m}_0 \rangle$ and outputs the following Parikh image of sequence $20t_1 + 20t_2 + 20t_3 + 20t_4 + 15t_5 + 15t_6 + 15t_7 + 15t_8$.

Other properties. The net is bounded, reversible and (lim-)live. Observe that lim-liveness of a continuous PN system implies structural liveness of the corresponding discrete PN [15]. Consequently, there exists an initial marking such that the discrete PN is also live.

7. Conclusions

In this work we have analysed the complexity of the most standard problems for continuous Petri nets. For almost all these problems, we have characterised their complexity class by designing new decision procedures and/or providing reductions from complete problems. We have also shown that the reachability set inclusion, undecidable for Petri nets, becomes decidable in the continuous framework. These

results are summarised in Table 2.

There are three fruitful possible extensions of this work. Other properties could be studied. A temporal logic provides a specification language for expressing properties. In Petri nets, the model checking problem lies on the boundary of decidability depending on the type of logics (branching versus linear, atomic propositions related to markings or to transition firings). We want to investigate this problem for continuous Petri nets. Hybrid Petri nets encompass both discrete and continuous Petri nets. So it would be interesting to examine the complexity and decidability of standard problems for the whole class or some appropriate subclasses of this formalism.

Table 2. Complexity bounds

Problems	Upper and lower bounds
(lim-)reachability	PTIME-complete in NC for lim-reachability (resp. reachability) when all transitions are fireable at least once (resp. and also in the reverse CPN) and the net is consistent
(lim-)coverability	PTIME-complete
(lim-)boundedness	PTIME-complete
(lim-)deadlock-freeness and (lim-)liveness	coNP-complete coNP-hard even for free-choice CPNs or for CPNs when all transitions are fireable at least once and the net is consistent
(lim-)reachability set inclusion	in EXPTIME coNP-hard even for reversibility in CPNs when all transitions are fireable at least once and the net is consistent

Acknowledgments. The authors would like to thank Jorge Júlvez and Manuel Silva for fruitful discussions on CPNs.

References

- [1] Avis, D., Fukuda, K., Picozzi, S.: On canonical representations of convex polyhedra, *Mathematical Software, Proceedings of the First International Congress of Mathematical Software* (A. M. Cohen, X.-S. Gao, N. Takayama, Eds.), World Scientific Publishing, 2002.
- [2] Bagnara, R., Hill, P. M., Zaffanella, E.: Not necessarily closed convex polyhedra and the double description method, *Formal Aspects of Computing*, **17**(2), 2005, 222–257.

- [3] Cabasino, M. P., Seatzu, C., Mahulea, C., Silva, M.: Fault diagnosis of manufacturing systems using continuous Petri nets, *Proceedings of the IEEE International Conference on Systems, Man and Cybernetics, Istanbul, Turkey*, IEEE, 2010.
- [4] Codenotti, B., Leoncini, M., Preparata, F. P.: The Role of Arithmetic in Fast Parallel Matrix Inversion, *Algorithmica*, **30**(4), 2001, 685–707.
- [5] David, R., Alla, H.: Continuous Petri Nets, *Proc. of the 8th European Workshop on Application and Theory of Petri Nets*, Zaragoza, Spain, 1987.
- [6] Desel, J., Esparza, J.: *Free Choice Petri Nets*, Cambridge Tracts in Theoretical Computer Science 40, 1995.
- [7] Desel, J., Neuendorf, K.-P., Radola, M.-D.: Proving Nonreachability by Modulo-Invariants, *Theor. Comput. Sci.*, **153**(1&2), 1996, 49–64.
- [8] Esparza, J., Nielsen, M.: Decidability Issues for Petri Nets - a survey, *Elektronische Informationsverarbeitung und Kybernetik*, **30**(3), 1994, 143–160.
- [9] Gudiño-Mendoza, B., López-Mellado, E., Alla, H.: Modeling and simulation of water distribution systems using timed hybrid Petri nets, *Simulation*, **88**(3), 2012, 329–347.
- [10] Júlvez, J., Recalde, L., Silva, M.: On reachability in autonomous continuous Petri net systems, *24th Int. Conf. on Application and Theory of Petri Nets* (W. van der Aalst, E. Best, Eds.), 2679, Springer, Eindhoven, The Netherlands, 2003.
- [11] Júlvez, J., Recalde, L., Silva, M.: Steady state performance evaluation of continuous mono-T-semiflow Petri nets, *Automatica*, **41**(4), May 2005, 605–616.
- [12] Papadimitriou, C. H.: *Computational complexity*, Addison-Wesley, 1994, ISBN 0201530821.
- [13] Papadimitriou, C. H., Steigliz, K.: *Combinatorial Optimization. Algorithms and Complexity*, Dover publications, second edition, 1998.
- [14] Recalde, L., Haddad, S., Silva, M.: Continuous Petri Nets: Expressive Power and Decidability Issues, *Int. Journal of Foundations of Computer Science*, **21**(2), 2010, 235–256.
- [15] Recalde, L., Teruel, E., Silva, M.: Autonomous Continuous P/T systems, *Application and Theory of Petri Nets 1999* (S. Donatelli, J. Kleijn, Eds.), 1639, Springer, Williamsburg, Virginia, USA, 1999.
- [16] Ross-Leon, R., Ramirez-Trevino, A., Morales, J. A., Ruiz-Leon, J.: Control of Metabolic Systems Modeled with Timed Continuous Petri Nets., *ACSD/Petri Nets Workshops*, 827, 2010.
- [17] Vázquez, C. R., Sutarto, H. Y., Boel, R. K., Silva, M.: Hybrid Petri Net Model of a Traffic Intersection in an Urban Network, *Proceedings of the IEEE International Conference on Control Applications, CCA 2010*, Yokohama, Japan, 2010.
- [18] Zerhouni, N., Alla, H.: Dynamic Analysis of Manufacturing Systems using Continuous Petri Nets., *Proceedings of the IEEE International Conference on Robotics and Automation*, 2, Cincinnati, OH, USA, 1990.