

# Time(d) Petri Net

Serge Haddad

LMF

ENS Paris-Saclay & CNRS

`haddad@lsv.fr`

Petri Nets 2023, June 26th 2019

- 1 Time and Petri Nets
- 2 Time Petri Net: Syntax and Semantic
- 3 Analysis of Time Petri Nets
- 4 More on Difference Bound Matrices
- 5 Timed Petri Nets: Syntax and Semantics
- 6 Analysis of Timed Petri Nets

# Outline

## 1 Time and Petri Nets

Time Petri Net: Syntax and Semantic

Analysis of Time Petri Nets

More on Difference Bound Matrices

Timed Petri Nets: Syntax and Semantics

Analysis of Timed Petri Nets

# Time in Discrete Event Systems

## Intuitively

A timed execution of a discrete event system (DES) is a finite or infinite sequence of events:  $e_1, e_2, \dots$  interleaved with (possibly null) delays.

*(generated by some operational model)*

## More formally

A timed execution of a DES is defined by two finite or infinite sequences:

- The sequence of states  $S_0, S_1, S_2, \dots$  such that:
  - 1  $S_0$  is the initial state,
  - 2  $S_i$  is the state of the system after the occurrence of  $e_i$ .
- The sequence of delays  $T_0, T_1, T_2, \dots$  such that:
  - 1  $T_0$  is the time elapsed before the occurrence of  $e_0$ ,
  - 2  $T_i$  is the time elapsed between the occurrences of  $e_i$  and  $e_{i+1}$ .

# A Timed Execution

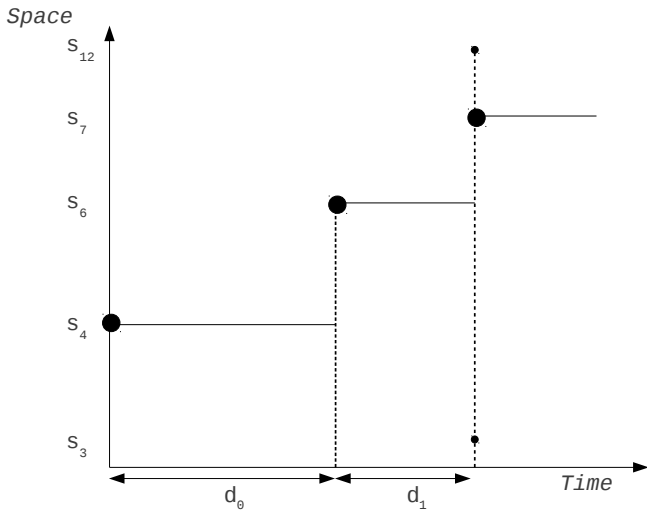

$$T_0 = d_0$$

$$T_1 = d_1$$

$$T_2 = 0$$

$$T_3 = 0$$

$$S_0 = S_4$$

$$S_1 = S_6$$

$$S_2 = S_3$$

$$S_3 = S_{12}$$

$$S_4 = S_7$$

# Time in Petri Nets

What are the events?

Atomicity versus non atomicity

- Beginning and end of transition firings
- Transition firings

What are the delays?

Timing requirements for transition firing

- Duration of transition firings  
(*asap requirement*)
- Appropriate age of tokens  
(*requirement on tokens*)
- Delay before firing  
(*requirement on delay between enabling and firing*)

# A Duration-Based Semantic

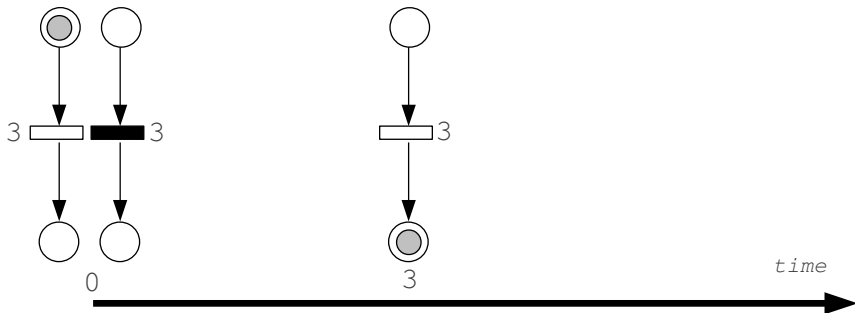

Requires to specify durations.

*Problem: most of the time, states are not reachable markings of the net.*

# A Token-Based Semantic

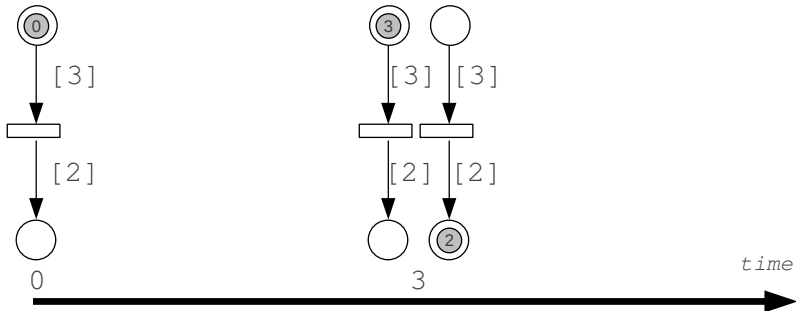

Requires to specify age constraints.

# A Delay-Based Semantic

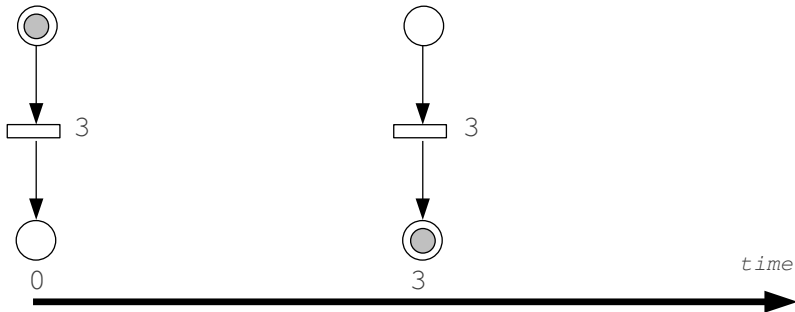

Requires to specify transition delays.



# Outline

## Time and Petri Nets

### 2 Time Petri Net: Syntax and Semantic

## Analysis of Time Petri Nets

## More on Difference Bound Matrices

## Timed Petri Nets: Syntax and Semantics

## Analysis of Timed Petri Nets

# Time Petri Net (TPN): Syntax

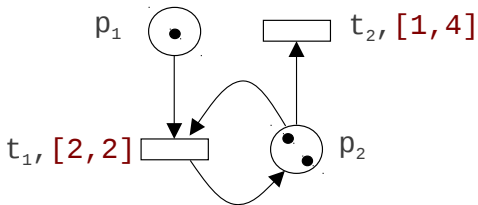

**Places:** logical part of the state

**Tokens:** current value of the logical part of the state also called *configuration*

**Transitions:** events, actions, etc.

**Arcs:** Pre and Post (logical) conditions of event occurrence

**Time intervals:** temporal conditions of event occurrence

# TPN: Transition Occurrence

## Logical part (*as in Petri nets*)

- The logical part of a configuration is a *marking*  $m$ , i.e. a number of tokens per place  $m(p)$ .
- A transition is *enabled* if the tokens required by the preconditions are present in the marking.

## Timed part

- There is an implicit clock per enabled transition  $t$  and its value  $\nu(t)$  defines the timed part of the state.
- The *clock valuation*  $\nu$  is the timed part of the configuration.
- An enabled transition  $t$  is *firable* if its clock value lies in its interval  $[e(t), l(t)]$ .

Notation:  $(m, \nu) \xrightarrow{t}$

# Illustration of Transition Occurrence

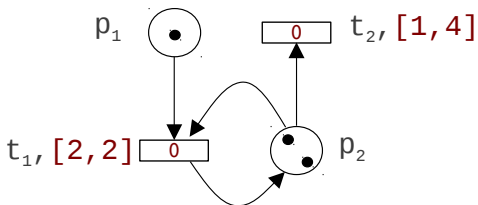

The initial configuration is  $(p_1 + 2p_2, (0, 0))$

Both  $t_1$  and  $t_2$  are enabled.

None is firable.

# Configuration Change by Time Elapsing

## Time elapsing $d$

- Time may elapse with updates of clocks if every clock value does not go *beyond the corresponding interval*.
- The marking is unchanged  $(m, \nu) \xrightarrow{d} (m, \nu + d)$

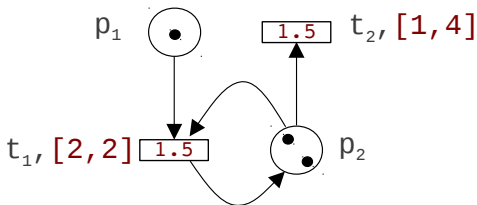

$$(p_1 + 2p_2, (0, 0)) \xrightarrow{1.5} (p_1 + 2p_2, (1.5, 1.5))$$

Now  $t_2$  is firable.

# Configuration Change by Transition Firing

## Transition firing $t$

- Tokens required by the precondition are consumed and tokens specified by the postcondition are produced.
- Clocks values of *newly enabled* transitions are reset leading to valuation  $\nu'$ .
- Thus  $(m, \nu) \xrightarrow{t} (m - Pre(t) + Post(t), \nu')$

## A transition $t'$ is newly enabled if

- 1  $t'$  is enabled in  $m - Pre(t) + Post(t)$
- 2 and  $t'$  is disabled in  $m - Pre(t)$  or  $t' = t$

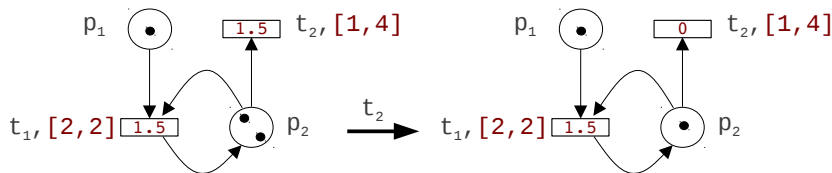

# An Execution

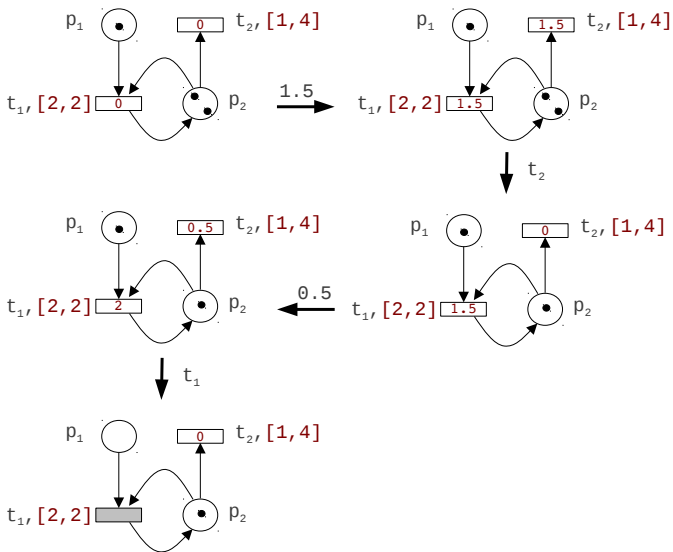

# An Equivalent Semantic

The timed part is defined by a *dynamic firing interval*  $[\bar{e}(t), \bar{l}(t)]$  associated with every enabled transition  $t$ .

## Firing of $t$

- A transition may fire if it is enabled and  $\bar{e}(t) = 0$ .
- Intervals of newly enabled transition are reinitialized:  $[\bar{e}(t), \bar{l}(t)] := [e(t), l(t)]$ .

## Time elapsing $d$

- Time  $d$  may elapse if for every enabled transition  $t$ ,  $d \leq \bar{l}(t)$ .
- Time intervals are accordingly updated  $[\max(0, \bar{e}(t) - d), \bar{l}(t) - d]$ .



# Revisiting the Execution

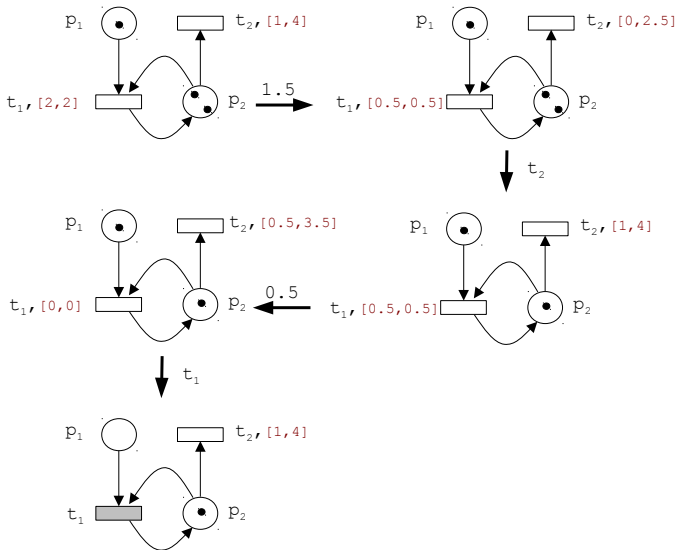

# Outline

Time and Petri Nets

Time Petri Net: Syntax and Semantic

3 Analysis of Time Petri Nets

More on Difference Bound Matrices

Timed Petri Nets: Syntax and Semantics

Analysis of Timed Petri Nets

# Properties

## Generic properties

- **Reachability** Given some state  $m$  can the system reach  $m$ ?
- **Non Termination** Does there exist an infinite firing sequence?
- **Deadlock** Does there exist a state from which no transition will fire?

## Specific properties

- **Temporal Logic** CTL, LTL, CTL\*, etc.

Is  $e$  eventually followed by  $e'$   
in every maximal sequence?

- **Timed Temporal Logic** TCTL, MTL, MITL, etc.

Is  $e$  eventually followed by  $e'$  within at most 10 t.u.  
in every maximal sequence?

# Overview

In TPNs,

all relevant properties are undecidable.

In *bounded* TPNs,

- many generic properties are decidable,
- some temporal model checking is decidable.

Boundedness problem

- Undecidable for TPNs
- A decidable sufficient condition: boundedness of the underlying PN

Key algorithms: class graph constructions

# What is a Class?

A class is a finite representation of an infinite set of reachable configurations.

A class is defined by:

- A marking  $m$ ;
- Let  $T_m$  be the set of enabled transitions from  $m$ .  
A set of variables  $\{x_0 = 0\} \cup \{x_t\}_{t \in T_m}$  with  $x_t$  the possible firing delay for  $t$ ;
- A matrix  $C$  (called a DBM) representing a set of constraints:

$$C(x_1, \dots, x_n) \equiv \bigwedge_{i,j} x_j - x_i \leq c_{ij}$$

# The Initial Class

## Definition

Let  $T_0 = \{t_1, \dots, t_k\}$  be the set of transitions enabled at  $m_0$ .

Then:

$$C(x_{t_1}, \dots, x_{t_k}) \equiv \bigwedge_{t \in T_0} e(t) \leq x_t \leq l(t)$$

## Example

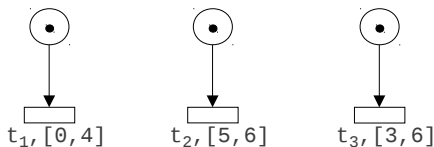

The initial class:  $C \equiv 0 \leq x_1 \leq 4 \wedge 5 \leq x_2 \leq 6 \wedge 3 \leq x_3 \leq 6$

# Firability of a Transition from a Class

Firability of  $t^*$  from class  $(m, C)$

In order to fire some  $t^* \in T_m$ , the following system must have a solution:

$$C_{t^*} \equiv C \wedge \bigwedge_{t \in T_m \setminus \{t^*\}} x_{t^*} \leq x_t$$

Example

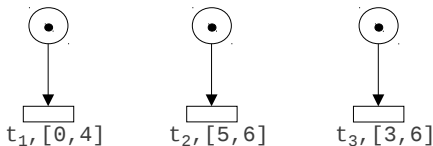

$$C_{t_1} \equiv 0 \leq x_1 \leq 4 \wedge 5 \leq x_2 \leq 6 \wedge 3 \leq x_3 \leq 6 \wedge x_1 \leq x_2 \wedge x_1 \leq x_3$$

# Firing a Transition from a Class

Let  $m \xrightarrow{t^*} m'$  and  $T_{m'}$  be the transitions enabled at  $m'$  with delays  $x'_t$  then:

- If  $t$  is newly enabled, the constraint is  $\tilde{C}_t \equiv (e(t) \leq x'_t \leq l(t))$
- Otherwise the constraints are inherited by  $\tilde{C}_t \equiv (x'_t = x_t - x_{t^*})$

Consequently, the constraints for firing delays after firing of  $t^*$  is

$$C' \equiv \exists x_{t_1} \dots \exists x_{t_k} C_{t^*} \wedge \bigwedge_{t \in T_{m'}} \tilde{C}_t \quad \text{with } T_m = \{t_1, \dots, t_k\}$$

**Example**

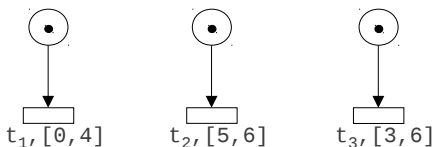

$$\begin{aligned} C_{t_1} \equiv & \exists x_1 \exists x_2 \exists x_3 \ 0 \leq x_1 \leq 4 \wedge 5 \leq x_2 \leq 6 \wedge 3 \leq x_3 \leq 6 \\ & \wedge x_1 \leq x_2 \wedge x_1 \leq x_3 \\ & \wedge x'_2 = x_2 - x_1 \wedge x'_3 = x_3 - x_1 \end{aligned}$$

**Problem:** this is no more a DBM-based representation of a class!



# Recovering the Class Representation

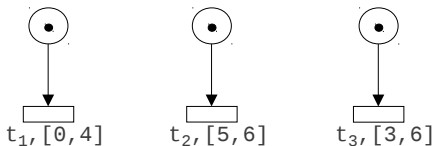

$$\begin{aligned} C_{t_1} \equiv & \exists x_1 \exists x_2 \exists x_3 \ 0 \leq x_1 \leq 4 \wedge 5 \leq x_2 \leq 6 \wedge 3 \leq x_3 \leq 6 \\ & \wedge x_1 \leq x_2 \wedge x_1 \leq x_3 \\ & \wedge x'_2 = x_2 - x_1 \wedge x'_3 = x_3 - x_1 \end{aligned}$$

## Recovery process

- Elimination of  $x_2$  and  $x_3$  by substitution

$$C_{t_1} \equiv \exists x_1 \ 0 \leq x_1 \leq 4 \wedge 5 \leq x'_2 + x_1 \leq 6 \wedge 3 \leq x'_3 + x_1 \leq 6$$

- Elimination of  $x_1$  by upper and lower bounds

$$\begin{aligned} C_{t_1} \equiv & \exists x_1 \ \max(0, 5 - x'_2, 3 - x'_3) \leq x_1 \leq \min(4, 6 - x'_2, 6 - x'_3) \\ \equiv & 1 \leq x'_2 \leq 6 \wedge 3 \leq x'_3 \leq 6 \wedge -3 \leq x'_3 - x'_2 \leq 1 \end{aligned}$$

# The Class Graph Algorithm

```
Add the initial class  $C$  to  $G$  (the class graph)
Insert( $Heap, C$ )
While  $Heap$  is not empty do
   $C \leftarrow Pick(Heap)$ 
  For all  $t$  firable from  $C$  do
     $C' \leftarrow Fire(C, t)$ 
    If  $C'$  does not belong to the graph then
      Add  $C'$  to  $G$ 
      Insert( $Heap, C'$ )
    Add  $C \xrightarrow{t} C'$  to  $G$ 
```

## Open issues (solved below)

- How to check the emptiness of a DBM?
- How to check whether two DBMs admit the same set of solutions?

# A Class Graph

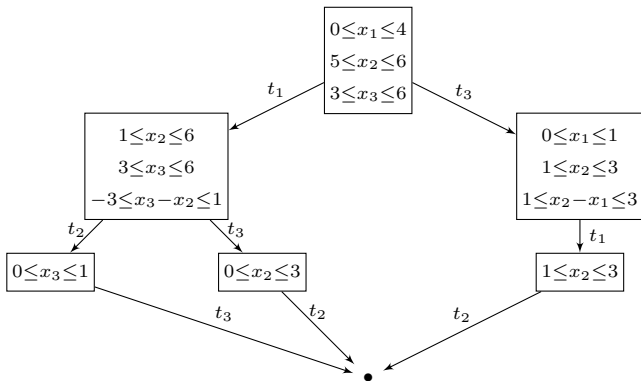
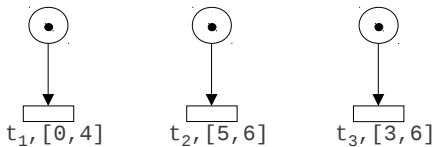

# Properties of the Class Graph

## Finiteness for bounded nets

- The number of reachable markings is finite.
- The absolute value of integers occurring in the DBMs are bounded by:  
 $\max(\max_{t \in T}(l(t) \mid l(t) \text{ finite}), \max_{t \in T}(e(t) \mid l(t) \text{ infinite}))$

## Trace and marking representation

- The untiming of every firing sequence of the TPN is a path of the graph.
- For every path of the graph there is a corresponding firing sequence.
- Thus the reachable markings are exactly those occurring in the graph.
- The reachable configurations are those of the classes occurring in the graph.

# Outline

Time and Petri Nets

Time Petri Net: Syntax and Semantic

Analysis of Time Petri Nets

4 More on Difference Bound Matrices

Timed Petri Nets: Syntax and Semantics

Analysis of Timed Petri Nets

# Properties of DBM

There exists a canonical representation for non empty DBM.

Canonization and emptiness checking can be done in polynomial time.

DBMs are effectively closed under:

- 1 **Projection**  $\exists x_1 C(x_1, x_2, \dots, x_n)$
- 2 **Relativization**  $\exists x_1 C(x_1, x_2 + x_1, \dots, x_n + x_1)$
- 3 **Past**  $\exists d C(x_1 + d, x_2 + d, \dots, x_n + d)$
- 4 **Future**  $\exists d C(x_1 - d, x_2 - d, \dots, x_n - d)$
- 5 **Reset**  $\exists x C(x, x_2, \dots, x_n) \wedge x_1 = 0$

# Canonization

Canonization is done by a shortest path computation.

Let the constraints be:

$$x_1 - x_0 \leq 3 \wedge -2 \leq x_2 - x_1 \leq 1 \wedge x_0 - x_2 \leq -2$$

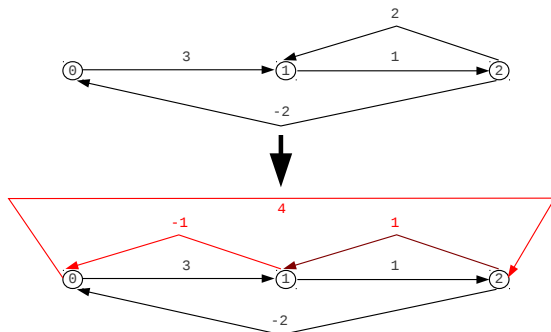

Then the canonized constraint is:

$$1 \leq x_1 - x_0 \leq 3 \wedge -1 \leq x_2 - x_1 \leq 1 \wedge -4 \leq x_0 - x_2 \leq -2$$

# The Canonization Algorithm

## Floyd-Warshall Algorithm

```
For all  $k$  do  
  For all  $j$  do  
    For all  $i$  do  
       $c_{ij} \leftarrow \min(c_{ij}, c_{ik} + c_{kj})$   
For all  $i$  do  
  If  $c_{ii} < 0$  Then Return(Empty DBM)
```



# Correctness of the Algorithm

## Correctness of the shortest path algorithm . . .

- The algorithm returns **Empty DBM** iff there is a negative cycle in the graph.
- Otherwise  $c_{ij}$  is the length of a shortest path from  $x_i$  to  $x_j$  and consequently  $c_{ik} \leq c_{ij} + c_{jk}$  for all  $k$ .

## implies correctness of the canonization.

- If there is a negative cycle in the graph there is no solution of the DBM.  
(*by transitivity one gets  $x_i - x_i < 0$* )
- Otherwise for all  $i, j$  there is no solution with  $x_j - x_i > c_{ij}$  and a solution with  $x_j - x_i = c_{ij}$  (*define  $x_i = 0$  and  $x_k = c_{ik}$  for all  $k \neq i$* )

# Outline

Time and Petri Nets

Time Petri Net: Syntax and Semantic

Analysis of Time Petri Nets

More on Difference Bound Matrices

5 Timed Petri Nets: Syntax and Semantics

Analysis of Timed Petri Nets

# Timed Petri Net (TdPN): Syntax

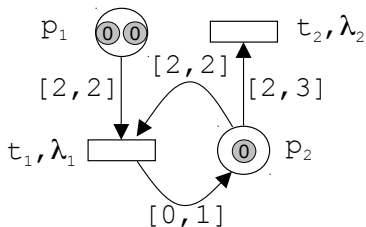

**Places:** both logical and timed part of the configuration

**Tokens:** have an age

**Transitions:** events, actions, etc.

**Labels:** observable behaviour

**Arcs:** Pre (resp. Post) conditions of event occurrence are multisets of timed intervals corresponding to required (resp. possible) age of consumed (resp. produced) tokens

# TdPN: Marking Formalization

A marking is a finite multiset of tokens with locations and ages:

$$m = \sum_{1 \leq i \leq r} a_i \cdot (p_i, \tau_i) \text{ with } r \geq 0 \text{ and } a_i > 0$$

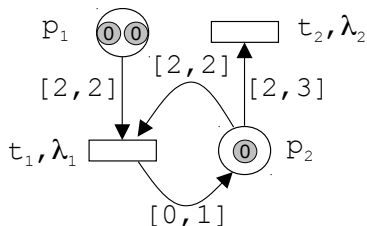

$$m_0 = 2 \cdot (p_1, 0) + (p_2, 0)$$

# TdPN: Time Elapsing

## Time elapsing $d$

- Time may elapse **without any restriction**.
- The age of tokens is accordingly updated  $m \xrightarrow{d} m'$  such that  $m' = \sum_{1 \leq i \leq r} a_i \cdot (p_i, \tau_i + d)$  when  $m = \sum_{1 \leq i \leq r} a_i \cdot (p_i, \tau_i)$

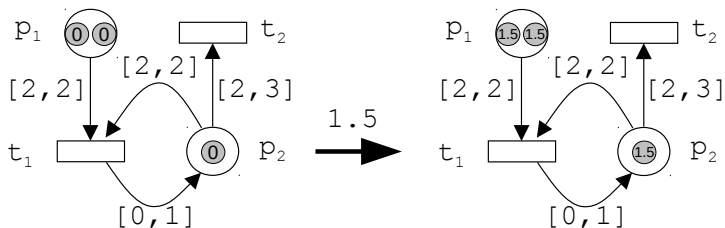

# TdPN: Transition Occurrence

## Firing a transition

- A transition  $t$  is fireable if for every input place  $p$  of  $t$  there exists an appropriate token, i.e. some  $(p, \tau_i)$  such that  $\tau_i \in Pre(p, t)$ .
- Tokens selected by the precondition are consumed.
- Tokens specified by the postcondition are produced with an initial age non deterministically chosen in the corresponding interval.

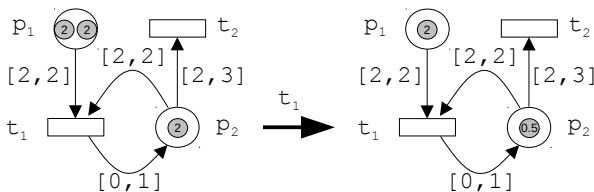

Observation: the generalization to bags of intervals is intuitive but requires technical machinery.

# TdPN: an Execution

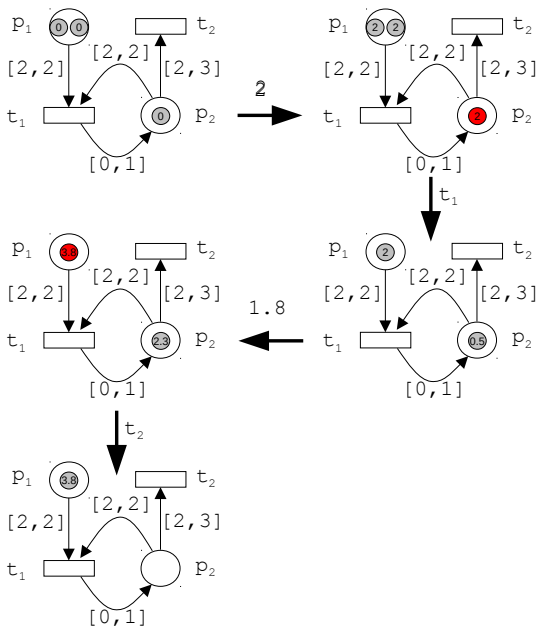

# Outline

Time and Petri Nets

Time Petri Net: Syntax and Semantic

Analysis of Time Petri Nets

More on Difference Bound Matrices

Timed Petri Nets: Syntax and Semantics

6 Analysis of Timed Petri Nets



# Reachability Analysis of Bounded TdPNs

The number of (reachable) configurations is infinite (and even uncountable). So one wants to partition configurations into *regions* such that:

- 1 The number of tokens of any place for two configurations in a region is the same.
- 2 Two configurations in a region allow the same transition firings and the new configurations belong to the same region.
- 3 If a configuration in a region letting time elapse reaches a new region every other configuration may reach the same region by time elapsing.
- 4 There is a finite representation of a region such that the discrete and time successors of the region are computable.
- 5 The number of regions is finite.

# A First Partition (two tokens and two markings)

Intervals check integer values.  
( $x$  and  $y$  are the ages of the two tokens)

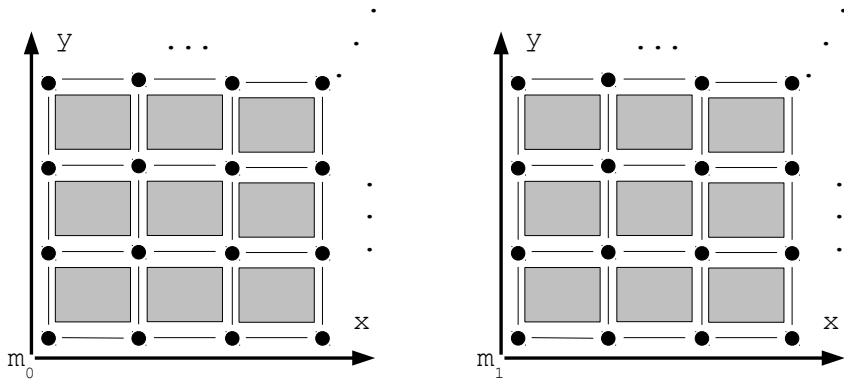

Why this partition is not appropriate?

# A Second Partition (two tokens and two markings)

The exact value of a token age is irrelevant when it is beyond the maximal constant of the TdPN (here 2)

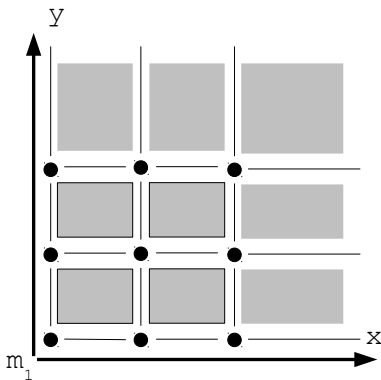
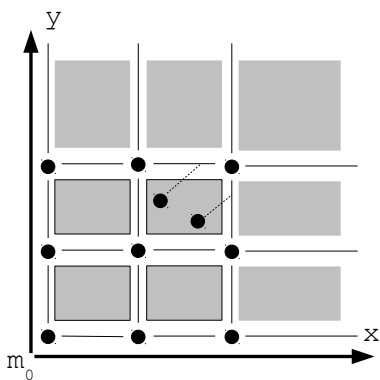

*Why this partition is not appropriate?*

# A Third Partition (two clocks and two locations)

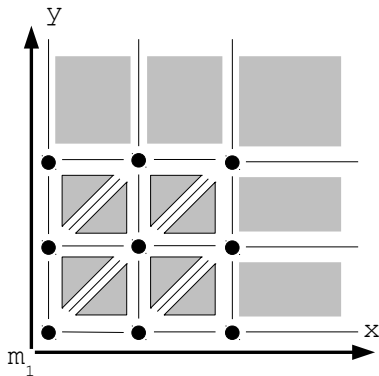
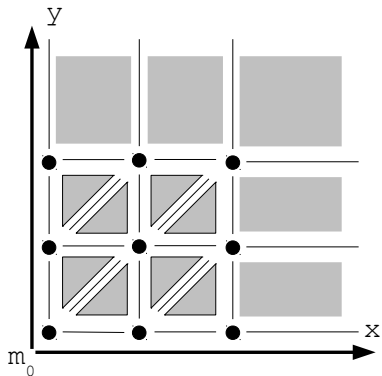

*Check that this partition is appropriate*

# The Region Graph: Illustration

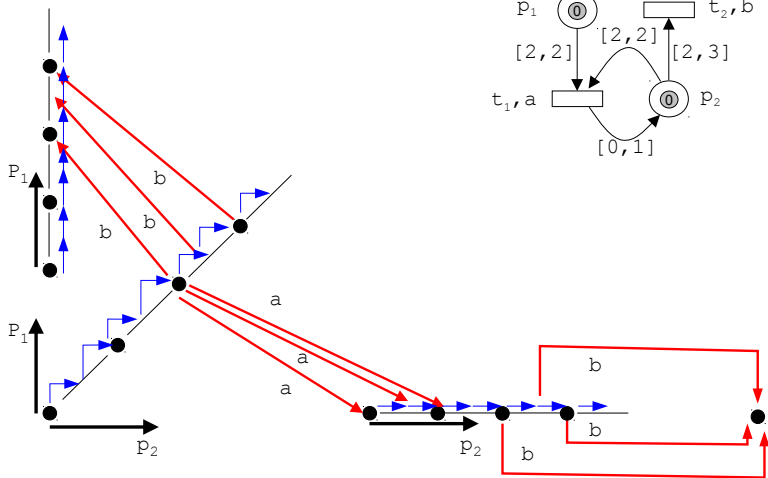

# About Reachability in the Region Graph

**Warning:** when a region is “reachable”, it does not mean that every configuration of the region is reachable.

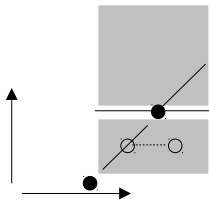

However it means that there is another reachable configuration of the region which differs only on the values of irrelevant ages of tokens.

Hence, in order to check the reachability of a configuration, it is enough to increase the maximal constant.

**Example:** reachability of  $((p_0, 1.7), (p_1, 2.3))$  requires to choose at least 3 as maximal constant.

# Formalizing Regions

A *region* of a TdPN is:

- $n + 1$  different and ordered fractional parts of the token ages with the null fractional part.
- The distribution of tokens on places and their integer part (when less or equal than the maximal constant) for every fractional part.
- The distribution of tokens with age greater than the maximal constant on places.

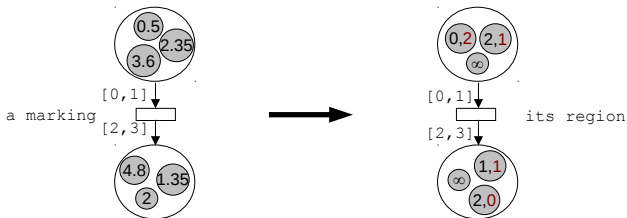

# Time Elapsing for Regions

- When there is a token with integer age, the next region is obtained by letting elapse some amount of time such that there is no token with integer age.
- When there is no token with integer age and some tokens with finite age, the next region is obtained by letting elapse the (minimal) amount time to get a token with integer age.
- When there is no token with finite age, time elapses inside the region.

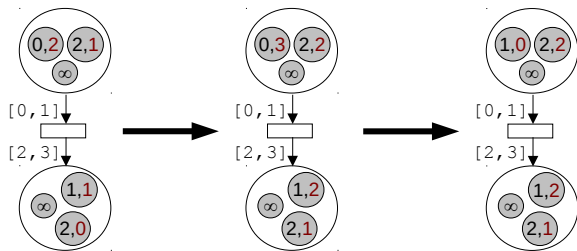

In the unbounded case, the corresponding region graph is **infinite** but it is a *well-structured transition system* and thus (for instance) coverability can be decided by a symbolic backward exploration.



# Main References

## On definition and analysis of TPNs

- B. Berthomieu, M. Menasche, A State enumeration approach for analyzing time Petri nets, 3rd European Workshop on Petri Nets, Varenna, Italy, 1982.
- B. Berthomieu, M. Diaz, Modeling and verification of time dependent systems using time Petri nets. IEEE Transactions on Software Engineering, 17(3):259-273, 1991.
- B. Bérard, F. Cassez, S. Haddad, D. Lime and O. H. Roux. The Expressive Power of Time Petri Nets. Theoretical Computer Science 474, pages 1-20, 2013.

## On definition and analysis of TdPNs

- V. Valero, D. Frutos-Escrig, F. R. F. Cuartero. On non-decidability of reachability for timed-arc Petri nets. In Proc. 8th Int. Work. Petri Nets and Performance Models (PNPM'99), pages 188-196. IEEE Computer Society Press, 1999
- P. A. Abdulla, A. Nylén. Timed Petri nets and bqos. In Proc. 22nd International Conference on Application and Theory of Petri Nets (ICATPN'01), volume 2075 of Lecture Notes in Computer Science, pages 53-70. Springer, 2001
- P. Bouyer, S. Haddad and P.-A. Reynier. Timed Petri Nets and Timed Automata: On the Discriminating Power of Zeno Sequences. Information and Computation 206(1), pages 73-107, 2008.